

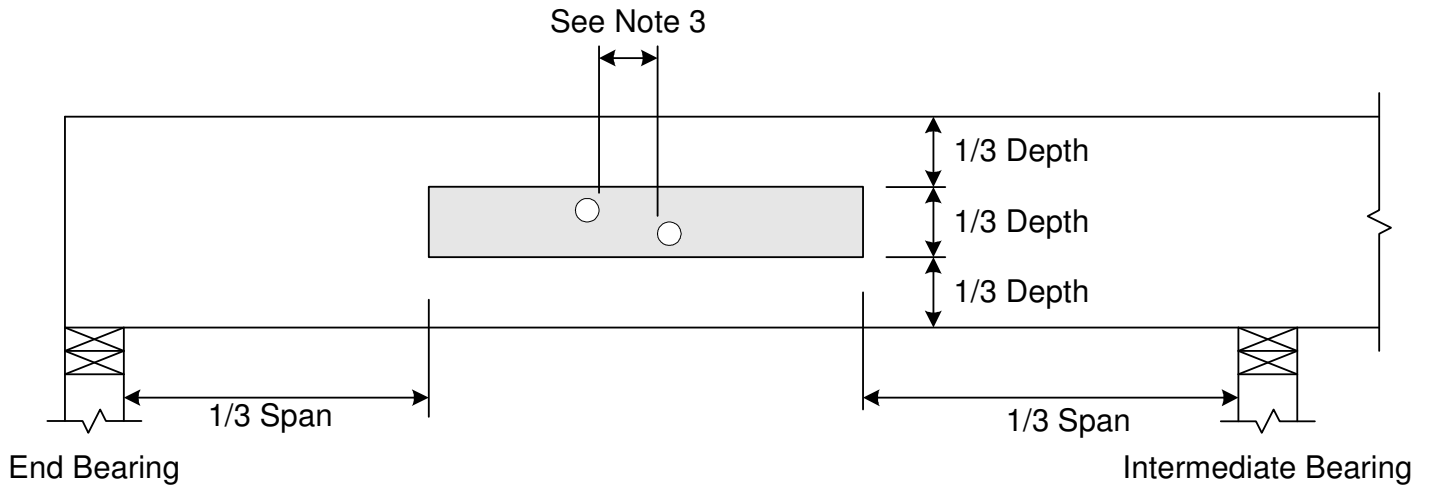

BOISE GLULAM® Allowable Hole Chart



Notes:

- 1) Square and rectangular holes are not permitted.
- 2) Round holes may be drilled or cut with a hole saw anywhere within the shaded area of the beam.
- 3) The horizontal distance between adjacent holes shall be at least two times the diameter of the larger hole. This restriction also applies to the location of access holes relative to bolt holes in multi-ply beams.
- 4) Do not drill more than three access holes in any four foot long section of beam.
- 5) The maximum round hole diameter permitted is:

Beam Depth	6" & 7 1/2"	9" and greater
Maximum Hole Diameter	1"	2"

- 6) These limitations apply to holes drilled for plumbing or wiring access only. The size and location of holes drilled for fasteners are governed by the provisions of the *National Design Specification® for Wood Construction*.
- 7) Beams deflect under load. Size holes to provide clearance where required.
- 8) This hole chart is valid for BOISE GLULAM and King Beam® 3000 beams, supporting uniform load only. For beams supporting concentrated loads and/or larger holes, contact Boise Cascade EWP Engineering.