



**Boise Cascade**  
*Engineered Wood Products*

# FIRE DESIGN & INSTALLATION GUIDE



## BCI® Joists and VERSA-LAM® Beams — Western (White City, OR)

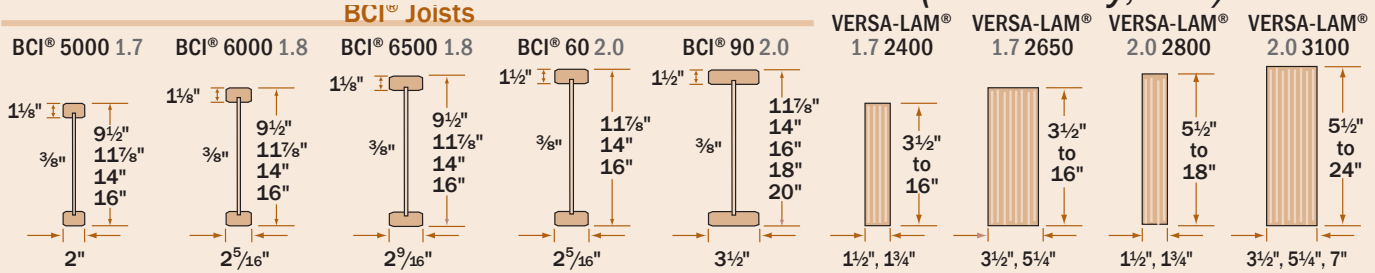

Some products may not be available in all markets. Contact your Boise Cascade EWP representative for availability. BCI® and VERSA-LAM® products shall be installed in dry-use applications only, per their respective ICC ESR evaluation reports.

## BCI® Joists and VERSA-LAM® Beams — Eastern (Lena, LA)

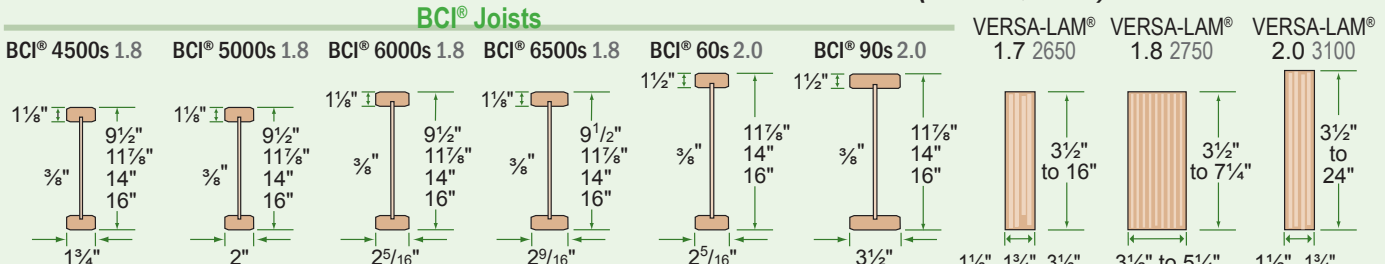

Some products may not be available in all markets. Contact your Boise Cascade EWP representative for availability.

## ALLJOIST® (St. Jacques, NB)

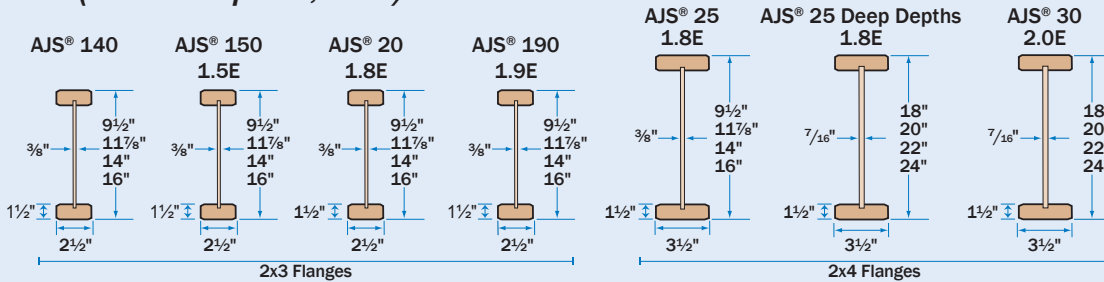

## BOISE GLULAM® (Homedale, ID)

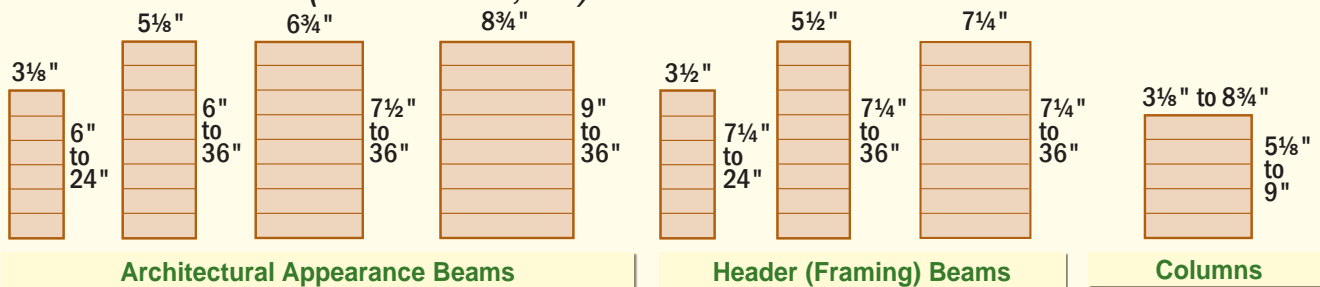

Larger widths and depths are available, contact your Boise Cascade EWP representative for availability

Product Profiles . . . . .	2	Two Hour Fire Resistance Rated Floor and Roof Assemblies. . . . .	13
Introduction, Residential Construction and Fire Safety . . . . .	3 - 5	Three Layer 5/8" Type C Gypsum Wallboard - BCI® and AJS® Joists . . . . .	13
Introduction, Prevention . . . . .	3	One-Hour Fire Resistance Rated Wall Assemblies . . . . .	14
Detection . . . . .	4	One Layer 5/8" Type X Gypsum Wallboard - VERSA-LAM® . . . . .	14
Containment, Evacuation . . . . .	5	One-Hour Fire Resistance Rated Rim Board Assemblies 15, 17, 18 . . . . .	15, 17, 18
Engineered Construction and Fire Safety. . . . .	6	Two-Hour Fire Resistance Rated Rim Board Assemblies . . . . .	16, 19
Types of Construction, Fire Resistance Ratings . . . . .	6	Sprinkler Attachments . . . . .	20
One Hour Fire Resistance Rated Floor and Roof Assemblies . . . . .	7 - 11	Commercial Sprinkler Pipe Weights . . . . .	20
Two Layers 5/8" Type X Gypsum Wallboard - BCI® and AJS® Joists . . . . .	7	Sprinkler Attachment Details FS01-FS21 . . . . .	20 - 23
Two Layers 1/2" Type C Gypsum Wallboard - BCI® and AJS® Joists . . . . .	8	Residential Sprinkler Details . . . . .	23
One Layer 5/8" Type C Gypsum Wallboard - BCI® 60/90 and AJS® Joists . . . . .	9	BCI® Joist Hole Location & Sizing . . . . .	24
One Layer 1/2" Type C Gypsum Wallboard - BCI® 60/90 and AJS® Joists . . . . .	10	AJS® Joist Hole Location & Sizing . . . . .	25
One Layer 5/8" Type C Gypsum Wallboard - BCI® 90 Joists and AJS® 25/30 Joists . . . . .	11	Calculated Fire Resistance . . . . .	26
One Layer 5/8" Type C Gypsum Wallboard & Strips - BCI® 90 Joists and AJS® 25/30 Joists . . . . .	12	Calculated Fire Resistance - VERSA-LAM® . . . . .	26
		Calculated Fire Resistance - BOISE GLULAM® . . . . .	27 - 28
		Frequently Asked Questions Regarding Fire Suppression . . . . .	29
		Lifetime Guarantee . . . . .	Back Cover

Boise Cascade manufactures and distributes quality Engineered Wood Products for modern construction throughout the United States and Canada. These products include BCI® & AJS® wood I-joists, VERSA-LAM® beams/columns/studs, BOISE GLULAM® beams/columns, and BOISE RIMBOARD® products. When compared to sawn lumber, Boise Cascade Engineered Wood Products provide higher strength, stiffness and dimensional consistency through more efficient use of raw materials to exacting industry quality standards required for modern construction.

This guide provides detailed information for the design and construction professional about the relationship between Boise Cascade Engineered Wood Products, national building codes, and actual fire events. For further information, contact Boise Cascade EWP Engineering at (800) 232-0788 or your local Boise Cascade representative.



## Residential Construction and Fire Safety

The performance of all structural building materials and systems degrade when exposed to fire and wood is no exception. Society's concern for fire safety is reflected in limitations and design requirements mandated through national building codes. Significant improvement in material and building performance can be realized with knowledge of fire safety design and evaluation involving prevention, detection, containment, and evacuation.

It is widely recognized that structure fires are highly variable in their size, rate of growth and intensity. Building contents (furniture, window coverings, electronic equipment, personal belongings) are the first items ignited and constitute the primary source of fuel in structure fires. Given all possible variations, there is no known way to determine how the fire will grow; therefore, each fire scenario is unique. If there is a fire in a structure, there is no "safe" amount of time that one can remain within the structure, even if everything was designed in accordance with all relevant codes and the time elapsed from ignition is known.

### Prevention

The proper design, construction, and maintenance of a building and its components are important steps in preventing a fire in the first place. The International Residential Code® (IRC®) includes chapters on mechanical system requirements (chapter 13), fuel gas (chapter 24), and electrical (chapter 33) that require appliances and electrical components that have the potential to accidentally initiate ignition to be tested and listed for their respective application, and to bear a label from an approved listing agency with that information.



## Detection

The IRC mandates the installation of smoke detectors in Chapter 3 – Building Planning. The requirement for smoke detectors in all new home construction gives most occupants three to five minutes to escape from a home before smoke and flame become life threatening. Since the introduction of smoke detectors into homes, fire deaths have been reduced by nearly 50 percent. Per section R314.3 of the IRC, smoke detectors are required in all bedrooms, outside bedrooms in the intermediate vicinity (hallway), and on each additional story, including basements.

Section R313 of the 2009 IRC mandates fire sprinkler systems for all one and two family dwellings, effective January 1, 2011. This new provision has received much debate within the residential construction and design community. At this time, several state and local jurisdictions have amended or revoked this provision. Please check with your local building official for further information regarding residential sprinkler requirements.

Attachment details for residential fire sprinkler systems are located on page 23 of this guide.

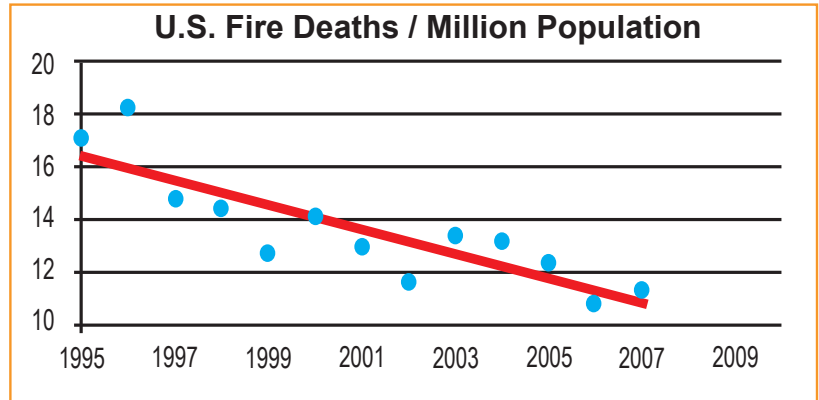

As shown by the figure on U.S. Fire Deaths per Million Population the U.S., fire deaths have seen a 30% decrease from 1995 to 2007. This reduction is primarily due to improved fire safety instituted through revisions to building codes and standards and occupant fire safety education. [Source: U.S. Fire Administration, "Fire in the United States", 2003-2007, and 1995-2004, [www.usfa.dhs.gov/statistics](http://www.usfa.dhs.gov/statistics)]

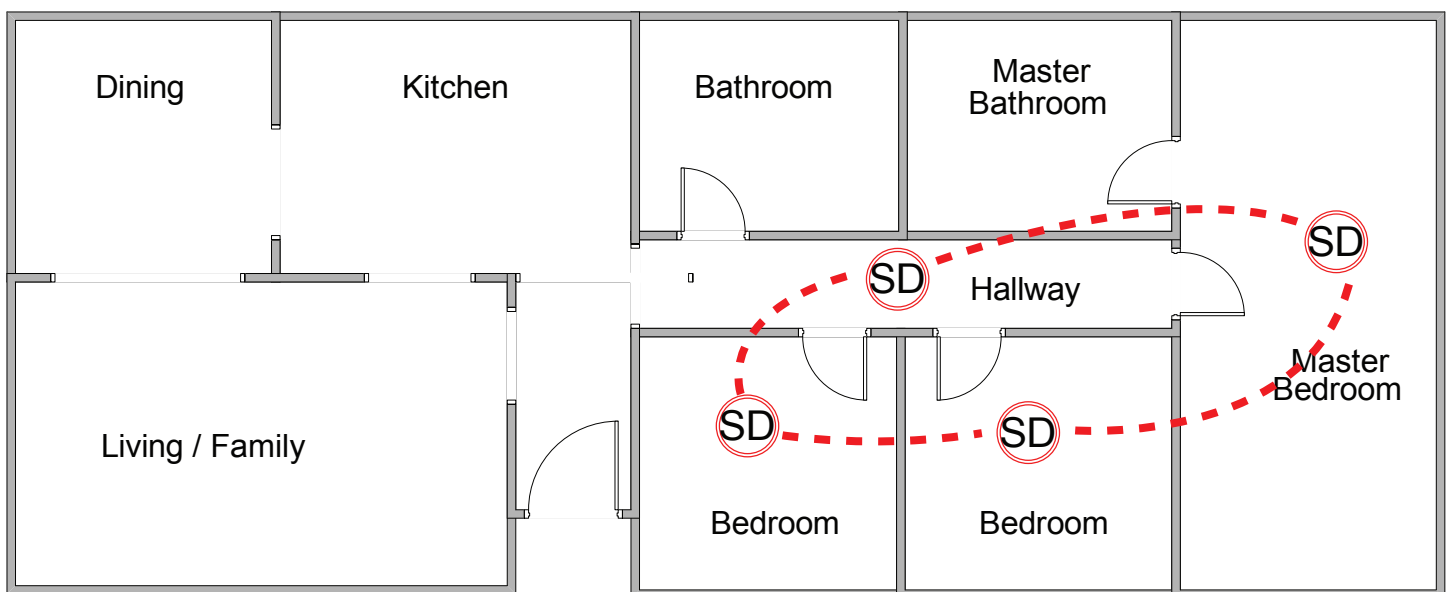

Example of Residential Smoke Detector Placement

## Containment

The ability to contain the fire within a certain space is dependent upon the fire resistance of the walls, doors, ceiling, and floors. The IRC addresses containment in chapters 3 and 6, prescribing separation with provisions for exterior walls and attached garages.

For residential basement ceilings, a simple, cost effective yet significant increase in fire resistance can be achieved by simply adding a single layer of 1/2" gypsum wallboard or 5/8" wood structural panel to the floor joists. The use of such membrane protection will very likely more than double the fire-endurance time for all commonly used wood floor joist systems, including dimension lumber, open web trusses and I-joists. In addition,

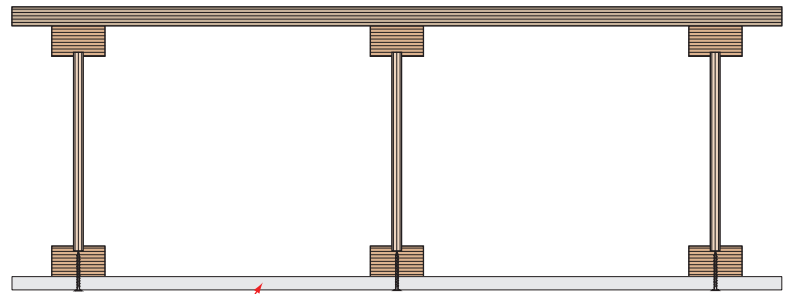

1/2" Gypsum Board

finishing the ceilings can increase the value of the home, increase floor performance, and reduce energy loss. It should be noted that this specific type of membrane protection is being mandated in the 2012 IRC for all joist types except dimension lumber, in structures that do not have automatic fire sprinkler systems or other approved fire protection.



## Evacuation

Emergency escape and rescue openings are addressed in chapter 3 of the IRC. Since the majority of residential fire deaths are the result of occupants sleeping during a fire, the IRC requires that all bedrooms and basements have adequate windows or doors for emergency escape purposes.

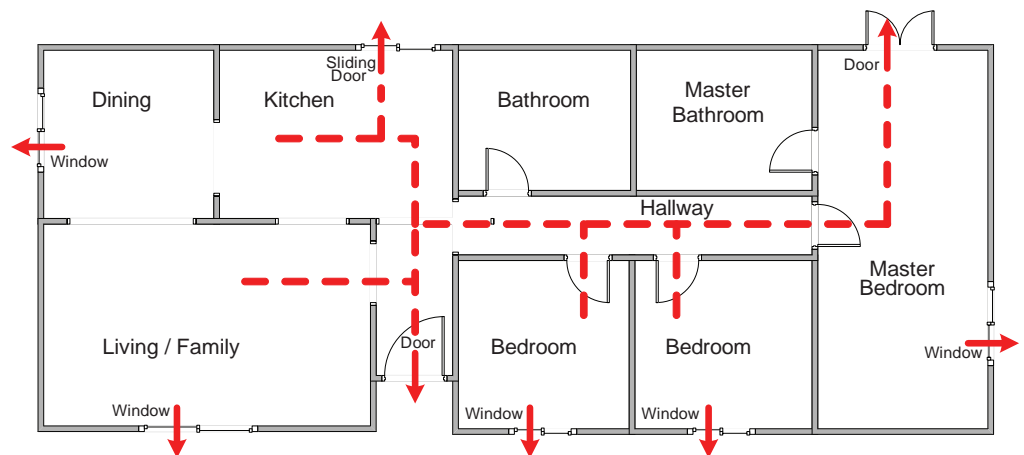

Example of Residential Evacuation Plan

Engineered construction refers to all buildings outside the scope of the IRC. U.S. building codes that address engineered construction include the International Building Code® (IBC®), the International Fire Code® (IFC®), the International Mechanical Code® (IMC®), the International Fuel Gas Code® (IFGC®), and the International Electrical Code® (IEC®). These national codes address the fire safety design issues mentioned previously, only in greater detail.

## Types of Construction

Construction type is a function of occupancy classification (group), number of stories and feet above grade plane, and area per story.

**Type I & II** – The building elements are of noncombustible materials. VERSA-LAM® and BOISE GLULAM® are allowed in Type I & II roof construction where a 1-hour fire resistance rating is required.

**Type III** – The exterior walls are of noncombustible materials or fire retardant treated wood and the interior building elements are of any material permitted by code. VERSA-LAM®, BCI® Joists, AJS® Joists, and BOISE GLULAM® are allowed in Type III construction everywhere except for exterior load bearing walls.

- See pages 26-28 for Calculated Fire Resistance for VERSA-LAM® and BOISE GLULAM®.
- See Fire Resistance Rated Floor and Roof Assemblies for BCI® / AJS® joists starting on page 7.
- See Fire Resistance Wall Assemblies for VERSA-LAM on page 14 for interior load bearing walls.

**Type IV (Heavy Timber Construction)** – The exterior walls are of noncombustible materials and the interior building elements are of solid or laminated wood without concealed spaces. Because of wood's ability to maintain structural capacity during fire, Heavy Timber allows large, open areas with exposed beams and columns. Minimum cross-sectional areas are required for framing members for Heavy Timber, please see the table below for minimum BOISE GLULAM® and VERSA-LAM® sizes.

- See pages 26-28 for Calculated Fire Resistance for VERSA-LAM® and BOISE GLULAM®.

Application	Min. Nominal Size per Code	Min. Available BOISE GLULAM®	Min. Available VERSA-LAM®
Floor Beam	6x10	5 <sup>1</sup> / <sub>8</sub> " x 10 <sup>1</sup> / <sub>2</sub> "	5 <sup>1</sup> / <sub>4</sub> " x 11 <sup>1</sup> / <sub>4</sub> "
Room Beam	4x6	3 <sup>1</sup> / <sub>8</sub> " x 7 <sup>1</sup> / <sub>2</sub> "	3 <sup>1</sup> / <sub>2</sub> " x 5 <sup>1</sup> / <sub>2</sub> "
Column – supporting floor load	8x8	8 <sup>3</sup> / <sub>4</sub> " x 9" 6 <sup>3</sup> / <sub>4</sub> " x 9"	7" x 9 <sup>1</sup> / <sub>4</sub> "
Column – supporting roof and/or ceiling loads only	6x8	8 <sup>3</sup> / <sub>4</sub> " x 9" 5 <sup>1</sup> / <sub>8</sub> " x 9"	5 <sup>1</sup> / <sub>4</sub> " x 8 <sup>5</sup> / <sub>8</sub> "

Boise Cascade laminated and solid decking may be installed as roof decking per the provisions listed in the Type IV section of the IBC.

**Type V** – The building elements are of any materials permitted by code. VERSA-LAM®, BCI® Joists, AJS® Joists, and BOISE GLULAM® are allowed in Type V construction everywhere.

- See pages 26-28 for Calculated Fire Resistance for VERSA-LAM® and BOISE GLULAM®.
- See Fire Resistance Rated Floor and Roof Assemblies for BCI® / AJS® joists starting on page 7.
- See Fire Resistance Wall Assemblies for VERSA-LAM on page 14 for interior load bearing walls.

## Fire Resistance Ratings

Fire resistance is the ability of materials or assemblies to prevent or restrict the passage of excessive heat, hot gases, or flames while continuing to support the structural loads. The performance of wall and floor assemblies exposed to fire is determined through testing in accordance with ASTM E 119 or NFPA 251 or CAN/ULC-S101. In a full-scale assembly test (at least 180 ft<sup>2</sup> for a floor assembly and 100 ft<sup>2</sup> for a wall assembly), a specimen is loaded to the maximum design load and directly exposed to flame. The rate of temperature rise is controlled to follow a standard time-temperature curve.

Results of full-scale fire endurance assembly tests provide a repeatable, relative measure of fire resistance based on three failure criteria: structural collapse, flame penetration, or excessive

temperature rise on the unexposed surface of the assembly. National building codes require that certain types of buildings or occupancy classes be constructed with floor and wall assemblies that provide fire endurance for a specified period of time based on these tests.

When required by national building codes, fire endurance rated assemblies are available for BCI®, AJS® and VERSA-LAM® products. The fire endurance assemblies in this guide can be further referenced in the International Building Code, ICC Evaluation Reports, Design for Code Acceptance 3 published by the American Wood Council, and/or assembly listings with APA – The Engineered Wood Association (APA Product Report PR-S201).

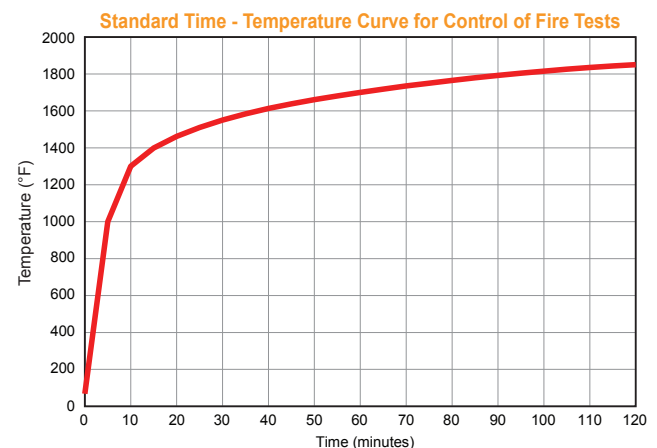

## Two Layers 5/8" Type X Gypsum Wallboard - BCI® and AJS® Joists

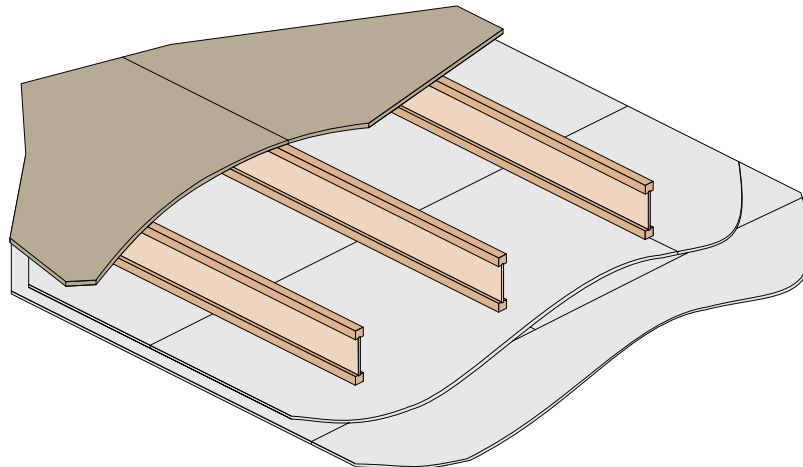

BASE ASSEMBLY	
Component	Material Specification
<b>Floor Topping (Optional)</b>	<b>Varies</b>
Reference sound ratings if applicable	
<b>Floor Sheathing</b>	<b>Min. 23/32 inch (18 mm) Wood Structural Panel</b>
A modified contact construction adhesive must be applied to the top of the joists prior to placing sheathing. The sheets shall be installed with their long edge perpendicular to the joists with end joists centered over the top flange of joists and staggered one joist spacing with adjacent sheets. Floor sheathing must be installed per code requirements.	
<b>Insulation (Optional)</b>	<b>Max 9½ inch (241 mm) Glass Fiber Insulation</b>
Reference sound ratings if applicable	
<b>Structural Members</b>	<b>Min. 9½ inch (241mm) Deep Joists</b>
Maximum 24 inch (610 mm) on center spacing. Minimum flange dimensions of 1½ inch (29mm) thick by 1½ inch (38mm) wide.	
<b>Resilient Channels (Optional)</b>	<b>Min. 0.019 inch (0.5mm) Galvanized Resilient Channel</b>
Attached perpendicular to the bottom flange of the joist with 1¼ inch (32mm) Type S drywall screws. Channels are spaced a maximum of 16 inches (406mm), 24 inches (610mm) on center when I-joists are spaced a maximum of 16 inches on center.	
<b>Ceiling</b>	<b>(2) Layers of 5/8 inch (16mm) Type X Gypsum Wallboard</b>
<p>Base Layer: Install with long dimension perpendicular to joist length. Attached to the bottom flange of the joists using 1¼ inch (32mm) Type W drywall screws at 24 inches (610 mm) on center. The end joints of the wallboard must be centered on the bottom flange of the joist and must be staggered the equivalent of two joist spacings with those of adjacent sheets.</p> <p>Face Layer: Install with long dimension perpendicular to joist length. Attached to the bottom flange of the joists through the first layer using 1½ inch (48mm) Type W drywall screws spaced at 12 inches (305mm) on center. The longitudinal joints of this layer must be offset 24 inches (610mm) from those of the base layer. The end joints must be centered on the bottom flange of the joists and offset a minimum of one joist spacing from those of the base layer. Additionally, face layer end joints are attached to the base layer with 1½ inch (38mm) Type G drywall screws at 12 inches (305mm) on center placed 2 inches (51mm) either side of the joint.</p> <p>With Resilient Channels: attached as described above except use 1¾ inch (35mm) and 1¼ inch (44mm) Type S screws for the base and face layer, respectively. The end joints of the wallboard must be centered on a resilient channel and must be staggered the equivalent of two joist spacings with those of adjacent sheets.</p> <p>Finish: The face layer joints must be covered with tape and coated with joint compound. Screw heads must also be covered with joint compound</p>	

SOUND RATING (w/Resilient Channel)		
Components	STC	IIC
Base Assembly with Carpet and Padding	54	68
Base Assembly with 3½" (89mm) Insulation	55	46
Base Assembly with additional layer of 5/8" Sheathing and 9½" Insulation	61	50
Base Assembly with Tarkett "Acoustiflor" vinyl and 3½" Insulation	59	50
Base Assembly with cushioned vinyl, ¾" Gypsum Concrete and 3½" Insulation	67	51

REFERENCE	
BCI® Joists	AJS® Joists
2006 / 2009 IBC® Table 720.1(3), Item Number 22-1.1/21-1.1	2006 / 2009 IBC® Table 720.1(3), Item Number 22-1.1/21-1.1
ICC-ES ESR 1336 and APA PR-S201 FR2	APA PR-S201 FR2
Similar to 2010 NBCC Table A-9.10.3.1.B, Assembly Num. F4, F9, F11, and F13, F15, F17, and F21.	Similar to 2010 NBCC Table A-9.10.3.1.B, Assembly Num. F4, F9, F11, and F13, F15, F17, and F21.

# One-Hour Fire Resistance Rated Floor and Roof Assemblies

## Two Layers 5/8" Type X Gypsum Wallboard - BCI® and AJS® Joists

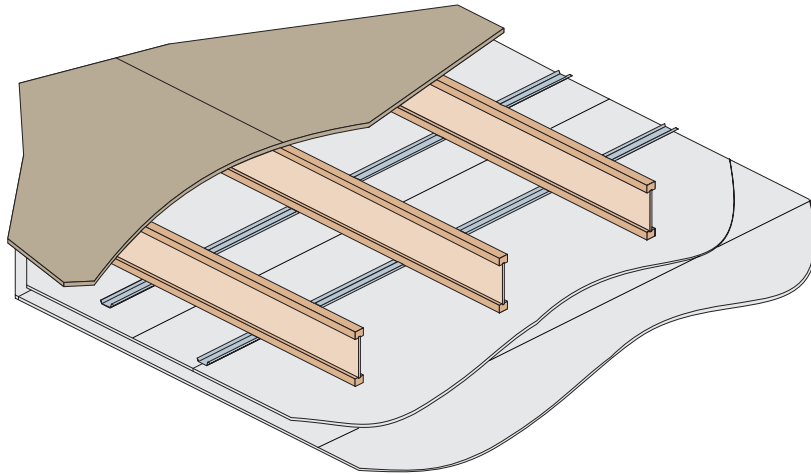

### BASE ASSEMBLY

Component	Material Specification
<b>Floor Topping (Optional)</b>	<b>Varies</b>
Reference sound ratings if applicable	
<b>Floor Sheathing</b>	<b>Min. 23/32 inch (18 mm) Wood Structural Panel</b>
A modified contact construction adhesive must be applied to the top of the joists prior to placing sheathing. The sheets shall be installed with their long edge perpendicular to the joists with end joists centered over the top flange of joists and staggered one joist spacing with adjacent sheets. Floor sheathing must be installed per code requirements..	
<b>Insulation (Optional)</b>	<b>Max 9½ inch (241 mm) Glass Fiber Insulation</b>
Reference sound ratings if applicable	
<b>Structural Members</b>	<b>Min. 9½ inch (241mm) Deep Joists</b>
Maximum 24 inch (610 mm) on center spacing. Minimum flange dimensions of 1½ inch (29mm) thick by 1½ inch (38mm) wide.	
<b>Resilient Channels (Optional)</b>	<b>Min. 0.019 inch (0.5mm) Galvanized Resilient Channel</b>
Attached perpendicular to the bottom flange of the joist with 1¼ inch (32mm) Type S drywall screws. Channels are spaced a maximum of 16 inches (406mm), 24 inches (610mm) on center when I-joists are spaced a maximum of 16 inches on center.	
<b>Ceiling</b>	<b>(2) Layers of ½ inch (13mm) Type C Gypsum Wallboard</b>
<p>Base Layer: Install with long dimension perpendicular to joist length. Attached to the bottom flange of the joists using 1¼ inch (32mm) Type W drywall screws at 12 inches (305 mm) on center. The end joints of the wallboard must be centered on the bottom flange of the joist and must be staggered the equivalent of two joist spacings with those of adjacent sheets.</p> <p>Face Layer: Install with long dimension perpendicular to joist length. Attached to the bottom flange of the joists through the first layer using 1½ inch (41mm) Type W drywall screws spaced at 12 inches (305mm) on center on intermediate joists and 6 inches (152mm) on center at end joints. The longitudinal joints of this layer must be offset 24 inches (610mm) from those of the base layer. The end joints must be centered on the bottom flange of the joists and offset a minimum of one joist spacing from those of the base layer. Additionally, face layer end joints are attached to the base layer with 1½ inch (38mm) Type G drywall screws at 8 inches (203mm) on center placed 6 inches (152mm) either side of the joint.</p> <p>With Resilient Channels: attached as described above except use 1¼ inch (32mm) and 1½ inch (41mm) Type S screws for the base and face layer, respectively. The end joints of the wallboard must be centered on a resilient channel and must be staggered the equivalent of two joist spacings with those of adjacent sheets.</p> <p>Finish: The face layer joints must be covered with tape and coated with joint compound. Screw heads must also be covered with joint compound.</p>	

### SOUND RATING (w/Resilient Channel)

Components	STC	IIC
Base Assembly with Carpet and Padding	54	68
Base Assembly with 3½" (89mm) Insulation	55	46
Base Assembly with additional layer of 5/8" Sheathing and 9½" Insulation	61	50
Base Assembly with Tarkett "Acoustiflor" vinyl and 3½" Insulation	59	50
Base Assembly with cushioned vinyl, ¾" Gypsum Concrete and 3½" Insulation	67	51

### REFERENCE

BCI® Joists	AJS® Joists
2006 / 2009 IBC® Table 720.1(3), Item Number 22-1.1/21-1.1	2006 / 2009 IBC® Table 720.1(3), Item Number 22-1.1/21-1.1
ICC-ES ESR 1336 and APA PR-S201 FR2	APA PR-S201 FR2
Similar to 2010 NBCC Table A-9.10.3.1.B, Assembly Num. F4, F9, F11, and F13, F15, F17, and F21.	Similar to 2010 NBCC Table A-9.10.3.1.B, Assembly Num. F4, F9, F11, and F13, F15, F17, and F21.



## One Layer 5/8" Type C Gypsum Wallboard - BCI® 60/90 and AJS® Joists

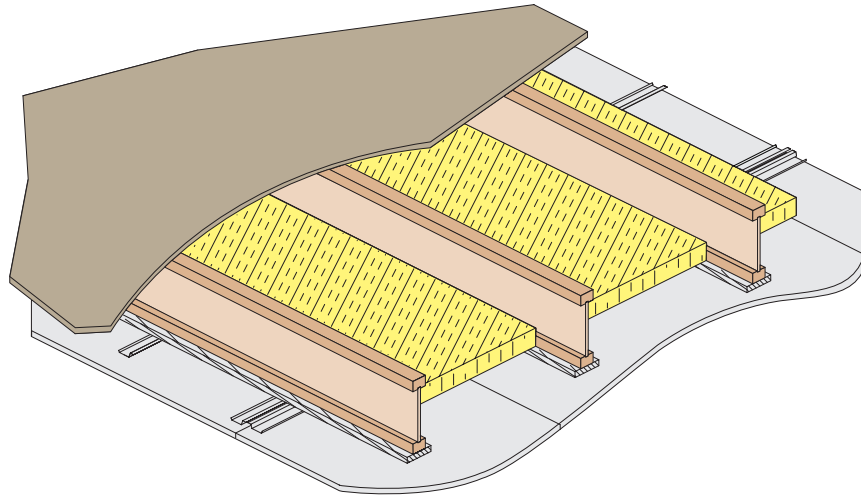

### BASE ASSEMBLY

Component	Material Specification
<b>Floor Topping (Optional)</b>	<b>Varies</b>
Reference sound ratings if applicable	
<b>Floor Sheathing</b>	<b>Min. 23/32 inch (18 mm) Wood Structural Panel</b>
A modified contact construction adhesive must be applied to the top of the joists prior to placing sheathing. The sheets shall be installed with their long edge perpendicular to the joists with end joists centered over the top flange of joists and staggered one joist spacing with adjacent sheets. Floor sheathing must be installed per code requirements.	
<b>Insulation</b>	<b>Min. 2 inch (51 mm) Mineral Fiber Insulation, Min. 3.5 pcf</b>
Installed adjacent to the bottom flange of the I-Joist and supported by the 1x4 furring strips. The ends of the batts must be centered over resilient channels.	
<b>Structural Members</b>	<b>Min. 9½ inch (241mm) Deep Joists</b>
Maximum 24 inch (610 mm) on center spacing. Minimum flange dimensions of 1½ inch (38mm) thick by 1½ inch (38mm) wide.	
<b>Furring Strips</b>	<b>1x4 (Nominal) Wood Furring Strips</b>
Centered on the bottom flange of the I-Joist and attached with 1½ inch (38mm) Type W screws at 24 inches (610mm) on center.	
<b>Resilient Channels</b>	<b>Min. 0.019 inch (0.5mm) Galvanized Resilient Channel</b>
Attached perpendicular to the bottom flange of the joist with 1⅞ inch (32mm) Type S drywall screws. Channels are spaced a maximum of 16 inches (406mm), 24 inches (610mm) on center when I-joists are spaced a maximum of 16 inches on center.	
<b>Ceiling</b>	<b>(1) Layer of 5/8 inch (16mm) Type C Gypsum Wallboard</b>
Installed with long dimension perpendicular to resilient channels and fastened with minimum 1⅞ inch (29mm) Type S drywall screws at 7 inches (178 mm) on center. The end joints of the wallboard must be staggered the equivalent of two joist spacings with those of adjacent sheets. Finish: The face layer joints must be covered with tape and coated with joint compound. Screw heads must also be covered with joint compound.	

### SOUND RATING (w/Resilient Channel)

Components	STC	IIC
Base Assembly with Carpet and Padding	52	66
Base Assembly with cushioned vinyl, 3/4" Gypsum Concrete	55	49
Base Assembly with cushioned vinyl, 3/4" Gypsum Concrete, 1/4" Acousti-Mat II	58	57

### REFERENCE

BCI® Joists	AJS® Joists
2006 / 2009 IBC® Table 720.1(3), Item Number 23-1.1 ICC-ES ESR 1336 and APA PR-S201 FR4	2006 / 2009 IBC® Table 720.1(3), Item Number 23-1.1 APA PR-S201 FR4

# One-Hour Fire Resistance Rated Floor and Roof Assemblies

## One Layer ½" Type C Gypsum Wallboard - BCI® 60/90 and AJS® Joists

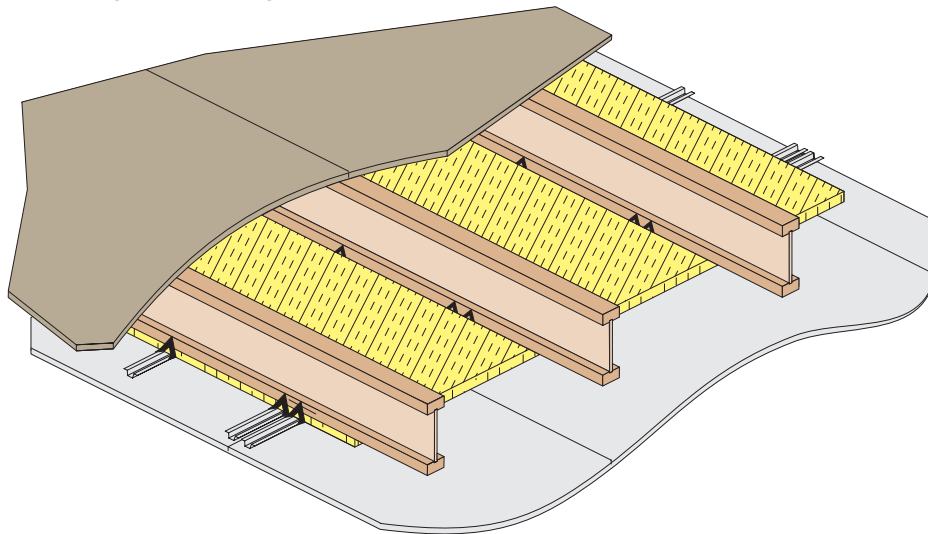

### BASE ASSEMBLY

Component	Material Specification
<b>Floor Topping (Optional)</b>	<b>Varies</b>
Reference sound ratings if applicable	
<b>Floor Sheathing</b>	<b>Min. 23/32 inch (18 mm) Wood Structural Panel</b>
A modified contact construction adhesive must be applied to the top of the joists prior to placing sheathing. The sheets shall be installed with their long edge perpendicular to the joists with end joists centered over the top flange of joists and staggered one joist spacing with adjacent sheets. Floor sheathing must be installed per code requirements.	
<b>Insulation</b>	<b>Min. 1 inch (25 mm) Mineral Fiber Insulation, Min. 6 pcf</b>
Installed parallel to the I-Joist between the furring channel and bottom flange. The sides of the insulation must butt against the support clips. The ends of the batts must be centered over furring channels.	
<b>Structural Members</b>	<b>Min. 9½ inch (241mm) Deep Joists</b>
Maximum 24 inch (610 mm) on center spacing. Minimum flange dimensions of 1½ inch (38mm) thick by 2 <sup>5</sup> / <sub>16</sub> inch (59mm) wide.	
<b>Furring Channel</b>	<b>Min. 0.019 inch (0.5mm) Hat Shaped Galv. Steel Channels</b>
Attached perpendicular to the bottom flange of the I-Joist, spaced a maximum of 24 inches (406mm) on center and doubled at each wallboard end joint extending to the next joist beyond each joint. The channels must be attached with Simpson Strong-Tie® CSC support clips (or equal) at each intersection with the joists. Clips must be nailed to the side of the joist bottom flange with one 8d x 1½ inch (38mm) long nail.	
<b>Ceiling</b>	<b>(1) Layer of ½ inch (13mm) Type C Gypsum Wallboard</b>
Installed with long dimension perpendicular to furring channels and fastened with minimum 1 inch (25mm) Type S drywall screws at 12 inches (305 mm) on center. The end joints of the wallboard must be staggered the equivalent of two joist spacings with those of adjacent sheets. Finish: The face layer joints must be covered with tape and coated with joint compound. Screw heads must also be covered with joint compound.	

### REFERENCE

BCI® 60/90 Joists	AJS® Joists
DCA #3 WIJ-1.4	DCA #3 WIJ-1.4

## One Layer 5/8" Type C Gypsum Wallboard - BCI® 90 Joists and AJS® 25/30 Joists

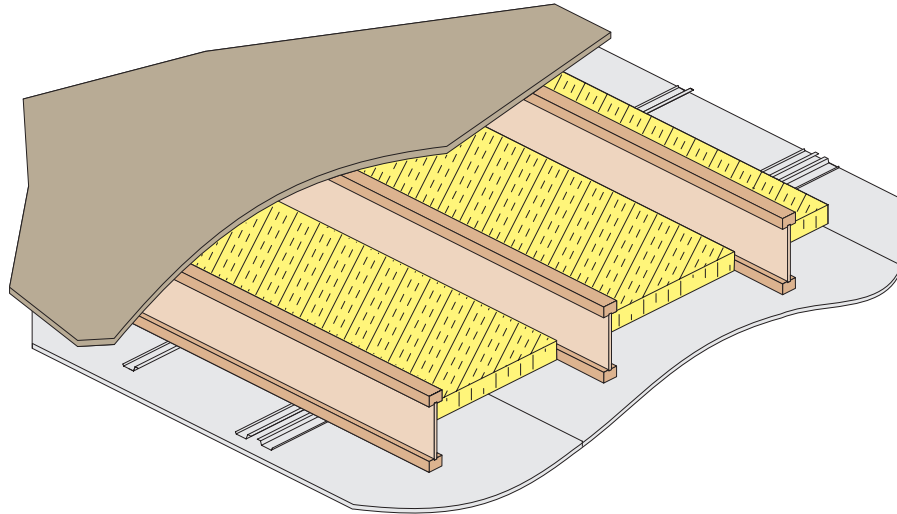

### BASE ASSEMBLY

Component	Material Specification
<b>Floor Topping (Optional)</b>	<b>Varies</b>
<b>Floor Sheathing</b>	<b>Min. 23/32 inch (18 mm) Wood Structural Panel</b>
A modified contact construction adhesive must be applied to the top of the joists prior to placing sheathing. The sheets shall be installed with their long edge perpendicular to the joists with end joists centered over the top flange of joists and staggered one joist spacing with adjacent sheets. Floor sheathing must be installed per code requirements.	
<b>Insulation</b>	<b>Min. 1½ inch (38mm) Mineral Fiber Insulation, Min. 2.8 pcf</b>
Installed adjacent to the bottom flange of the I-Joist and supported by the furring channels. The ends of the batts shall be centered over resilient channels.	
<b>Structural Members</b>	<b>Min. 9½ inch (241mm) Deep Joists</b>
Maximum 24 inch (610 mm) on center spacing. Minimum flange dimensions of 1½ inch (38mm) thick by 3½ inch (89mm) wide.	
<b>Resilient Channels</b>	<b>Min. 0.019 inch (0.5mm) Resilient Channels</b>
Attached perpendicular to the bottom flange of the I-Joist with 1½ inch (41mm) Type S drywall screws. Channels are spaced a maximum of 16 inches (406mm) on center and doubled at each wallboard end joint extending to the next joist beyond each joint.	
<b>Ceiling</b>	<b>(1) Layer of 5/8 inch (16mm) Type C Gypsum Wallboard</b>
Installed with long dimension perpendicular to resilient channels and fastened with minimum 1½ inch (29mm) Type S drywall screws spaced at 12 inches (305mm) on center on intermediate joists and 8 inches (203mm) on center at end joints. The end joints of the wallboard must be staggered the equivalent of two joist spacings with those of adjacent sheets. Finish: The face layer joints must be covered with tape and coated with joint compound. Screw heads must also be covered with joint compound.	

### SOUND RATING\*

Components	STC	IIC
Base Assembly with cushioned vinyl	51	46
Base Assembly with Carpet and Padding	51	64
Base Assembly with cushioned vinyl, Gypsum Concrete	60	50
Base Assembly with Carpet and Padding, Gypsum Concrete	60	65

### REFERENCE

BCI® 90 Joists	AJS® 25/30 Joists
2006/2009 IBC® Table 720.1(3), Item Num. 26-1.1/25-1.1	
2012 IBC® Table 721.1(3), Item Num. 25-1.1	
2010 NBCC Table A-9.10.3.1.B., Assembly Num. F10, F14, and F20	
DCA 3, WIJ-1.2	
ICC-ES ESR 1336, Figure 5 and APA PR-S201 FR6	APA PR-S201 FR6

\* Sound ratings from the American Wood Council publication Design for Code Acceptance 3. Retrieved from <http://www.awc.org/publications/DCA/DCA3/DCA3.pdf>.

# One-Hour Fire Resistance Rated Floor and Roof Assemblies

## One Layer 5/8" Type C Gypsum Wallboard & Strips - BCI® 90 Joists and AJS® 25/30 Joists

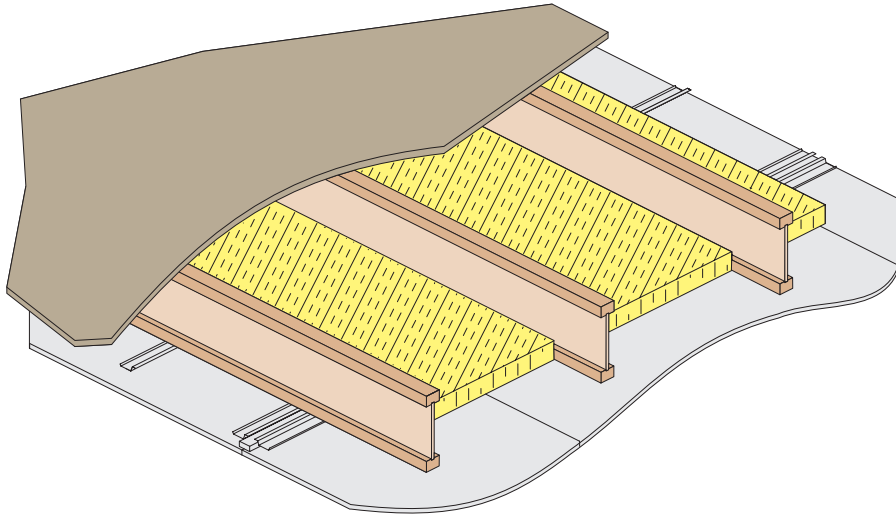

### BASE ASSEMBLY

Component	Material Specification
<b>Floor Topping (Optional)</b>	<b>Varies</b>
Reference sound ratings if applicable	
<b>Floor Sheathing</b>	<b>Min. 23/32 inch (18 mm) Wood Structural Panel</b>
A modified contact construction adhesive must be applied to the top of the joists prior to placing sheathing. The sheets shall be installed with their long edge perpendicular to the joists with end joists centered over the top flange of joists and staggered one joist spacing with adjacent sheets. Floor sheathing must be installed per code requirements.	
<b>Insulation</b>	<b>Min. 1½ inch (38mm) Mineral Fiber Insulation, Min. 3.5 pcf</b>
Installed adjacent to the bottom flange of the I-Joist and supported by the furring channels. The ends of the batts shall be centered over resilient channels.	
<b>Structural Members</b>	<b>Min. 9½ inch (241mm) Deep Joists</b>
Maximum 24 inch (610 mm) on center spacing. Minimum flange dimensions of 1½ inch (38mm) thick by 3½ inch (89mm) wide.	
<b>Furring Channels</b>	<b>Min. 0.019 inch (0.5mm) Resilient Channels</b>
Attached perpendicular to the bottom flange of the I-Joist with 1¼ inch (32mm) Type W drywall screws. Channels are spaced a maximum of 16 inches (406mm) on center and doubled at each wallboard end joint extending to the next joist beyond each joint.	
<b>Gypsum Strips</b>	<b>2 inch (51mm) wide by ½ inch (13mm) Type C Gypsum Wallboard</b>
Installed perpendicular to the joists above each end joint of the 5/8 inch (16mm) gypsum wallboard. The strips are attached with one 1¼ inch (32mm) Type W drywall screw at each joist."	
<b>Ceiling</b>	<b>(1) Layer of 5/8 inch (16mm) Type C Gypsum Wallboard</b>
Installed with long dimension perpendicular to resilient channels and fastened with minimum 1¼ inch (29mm) Type S drywall screws spaced at 8 inches (203mm) on center. The end joints of the wallboard must be staggered the equivalent of two joist spacings with those of adjacent sheets. Finish: The face layer joints must be covered with tape and coated with joint compound. Screw heads must also be covered with joint compound.	

### SOUND RATING (w/Resilient Channel)

Components	STC	IIC
Base Assembly with Carpet and Padding	55	62
Base Assembly with cushioned vinyl, 5/8" Gypsum Concrete	58	45
Base Assembly with cushioned vinyl, Gypsum Concrete, 1/4" Acousti-Mat II	61	53

### REFERENCE

BCI® 90 Joists	AJS® 25/30 Joists
ICC-ES ESR 1336 and APA PR-S201 FR7	APA PR-S201 FR7

## Three Layer 5/8" Type C Gypsum Wallboard - BCI® and AJS® Joists

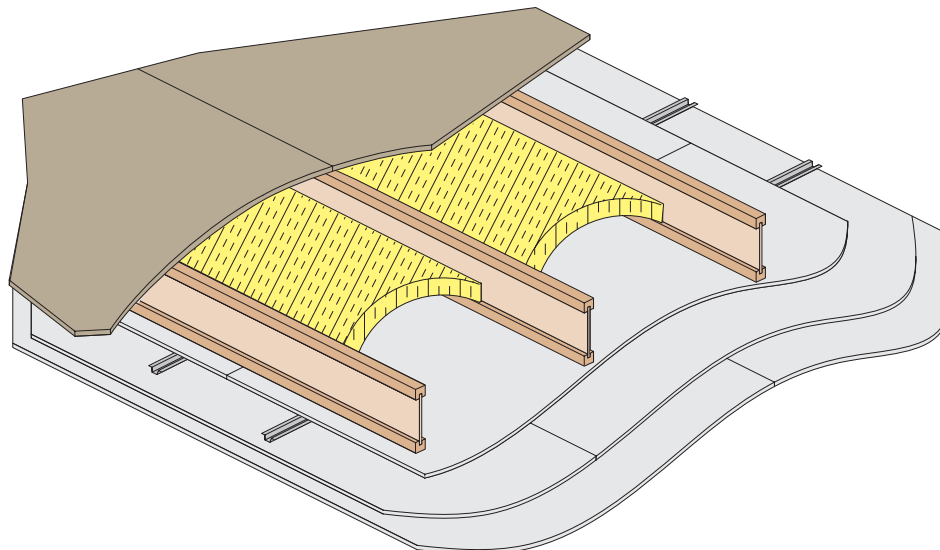

### BASE ASSEMBLY

Component	Material Specification
<b>Floor Topping (Optional)</b>	<b>Varies</b>
Reference sound ratings if applicable	
<b>Floor Sheathing</b>	<b>Min. 23/32 inch (18 mm) Wood Structural Panel</b>
A modified contact construction adhesive must be applied to the top of the joists prior to placing sheathing. The sheets shall be installed with their long edge perpendicular to the joists with end joists centered over the top flange of joists and staggered one joist spacing with adjacent sheets. Floor sheathing must be installed per code requirements.	
<b>Insulation</b>	<b>Max. 3½ inch (89mm) Unfaced Glass Fiber Insulation</b>
Friction fitted between I-Joists and supported by stay wires spaced 12 inches (305mm) on center along the joist bottom flange.	
<b>Structural Members</b>	<b>Min. 9½ inch (241mm) Deep Joists</b>
Maximum 24 inch (610 mm) on center spacing. Minimum flange dimensions of 1½ inch (29mm) thick by 2 inch (51mm) wide.	
<b>Furring Channels</b>	<b>Min. 0.019 inch (0.5mm) Hat Shaped Galv. Steel Channels</b>
Attached perpendicular to the bottom flange of the I-Joist with 1½ inch (41mm) Type S drywall screws penetrating through the wallboard base layer into each joist flange. Channels are spaced a maximum of 16 inches (406mm) on center and doubled at each wallboard end joint extending to the next joist beyond each joint.	
<b>Ceiling</b>	<b>(3) Layer of 5/8 inch (16mm) Type C Gypsum Wallboard</b>
<p>Base Layer: Install with long dimension perpendicular to joist length. Attached to the bottom flange of the joists using 1½ inch (41mm) Type S drywall screws at 12 inches (305 mm) on center. The end joints of the wallboard must be centered on the bottom flange of the joist and must be staggered the equivalent of two joist spacings with those of adjacent sheets.</p> <p>Middle Layer: attached to furring channels using 1-inch (25mm) Type S drywall screws at 12 inches (305mm) on center with the long dimension perpendicular to furring channels. End joints must be staggered from end joints of adjacent sheets and end joints on the face layer.</p> <p>Face Layer: attached to furring channels through the middle layer using 1½ inch (41mm) Type S drywall screws spaced at 8 inches (203mm) on center with long dimension perpendicular to furring channel. End joints must be staggered from end joints of adjacent sheets and staggered 32 inches (813mm) end joints on the middle layer. Edge joints (long dimension) must be offset 24 inches (610mm) from those of the middle layer.</p> <p>Finish: The face layer joints must be covered with tape and coated with joint compound. Screw heads must also be covered with joint compound.</p>	

### REFERENCE

BCI® Joists	AJS® Joists
2006 / 2009 IBC® Table 720.1(3), Item Number 29-1.1/28-1.1	2006 / 2009 IBC® Table 720.1(3), Item Number 29-1.1/28-1.1
ICC-ES ESR 1336 and APA PR-S201 FR8	APA PR-S201 FR8

# One-Hour Fire Resistance Rated Wall Assemblies

## One Layer 5/8" Type X Gypsum Wallboard – VERSA-LAM®

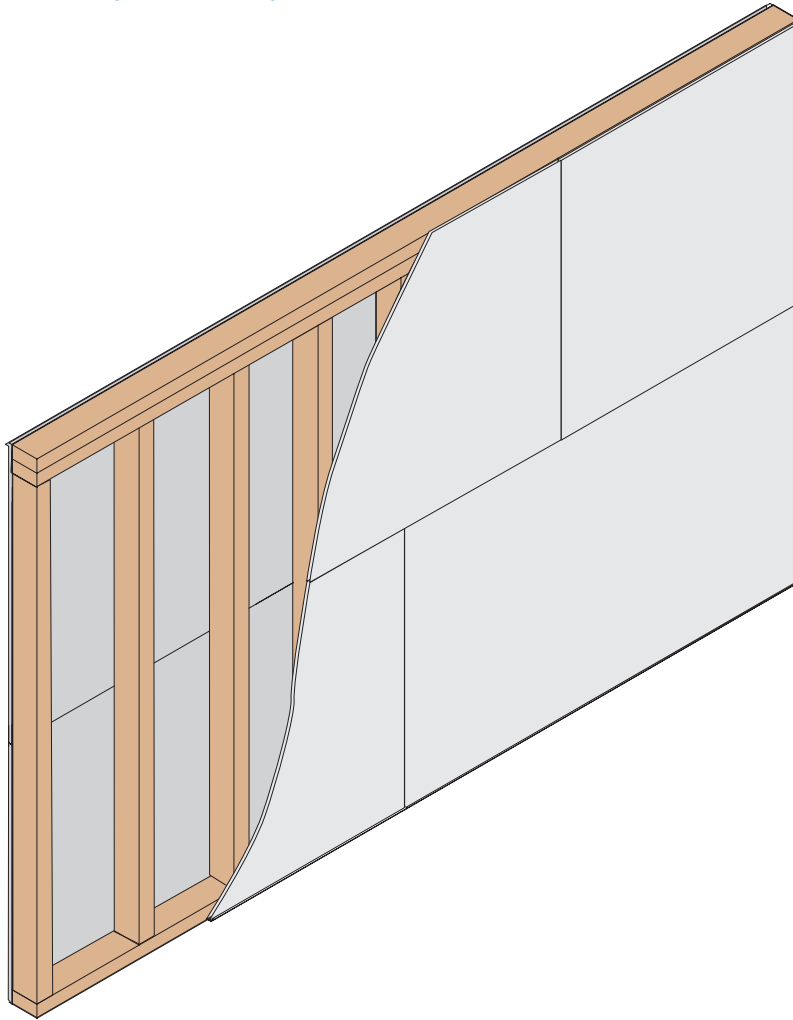

### BASE ASSEMBLY

Component	Material Specification
<b>Structural Members</b>	<b>Min. 1½ inch (28mm) X 5½ inch (140mm) VERSA-LAM®</b>
<p>Studs spaced no more than 16 inches (406mm) on center.            For prescriptive wall systems VERSA-LAM® may be used as a direct replacement of solid-sawn studs.            For engineered wall systems the axial compressive stress of an individual stud must not exceed the least of the following:</p> <ul style="list-style-type: none"> <li>• 525 psi (3620 kPa) (limitation associated with compression perpendicular to grain of VERSA-LAM® sill plate)</li> <li>• <math>0.46F_c'</math>, where <math>F_c'</math> is the compression design value parallel to grain, adjusted by all applicable adjustment factors in accordance with the NDS, including the column stability factor, <math>C_p</math>.</li> </ul>	
<b>Insulation (Optional)</b>	<b>Varies</b>
Fitted between studs.	
<b>Interior Membrane</b>	<b>(1) Layer of 5/8 inch (16mm) Type X Gypsum Wallboard</b>
<p>Applied horizontally or vertically with vertical joints over studs. Attached with 2¼ inch (57mm) Type S or Type W drywall screws spaced 7 inches (178mm) on center along each stud.            Finish: The gypsum wallboard joints must be covered with tape and coated with joint compound. Screw heads must also be covered with joint compound.</p>	
<b>Exterior Membrane</b>	<b>(1) Layer of 5/8 inch (16mm) Type X Gypsum Wallboard</b>
<p>Applied horizontally or vertically with vertical joints over studs. Attached with 2¼ inch (57mm) Type S or Type W drywall screws spaced 7 inches (178mm) on center along each stud.            Finish: The gypsum wallboard joints must be covered with tape and coated with joint compound. Screw heads must also be covered with joint compound.</p>	

### REFERENCE

#### VERSA-LAM®

2006 / 2009 IBC® Table 720.1(2), Item Number 15-1.14

ICC-ES ESR 1040

## End Wall Application

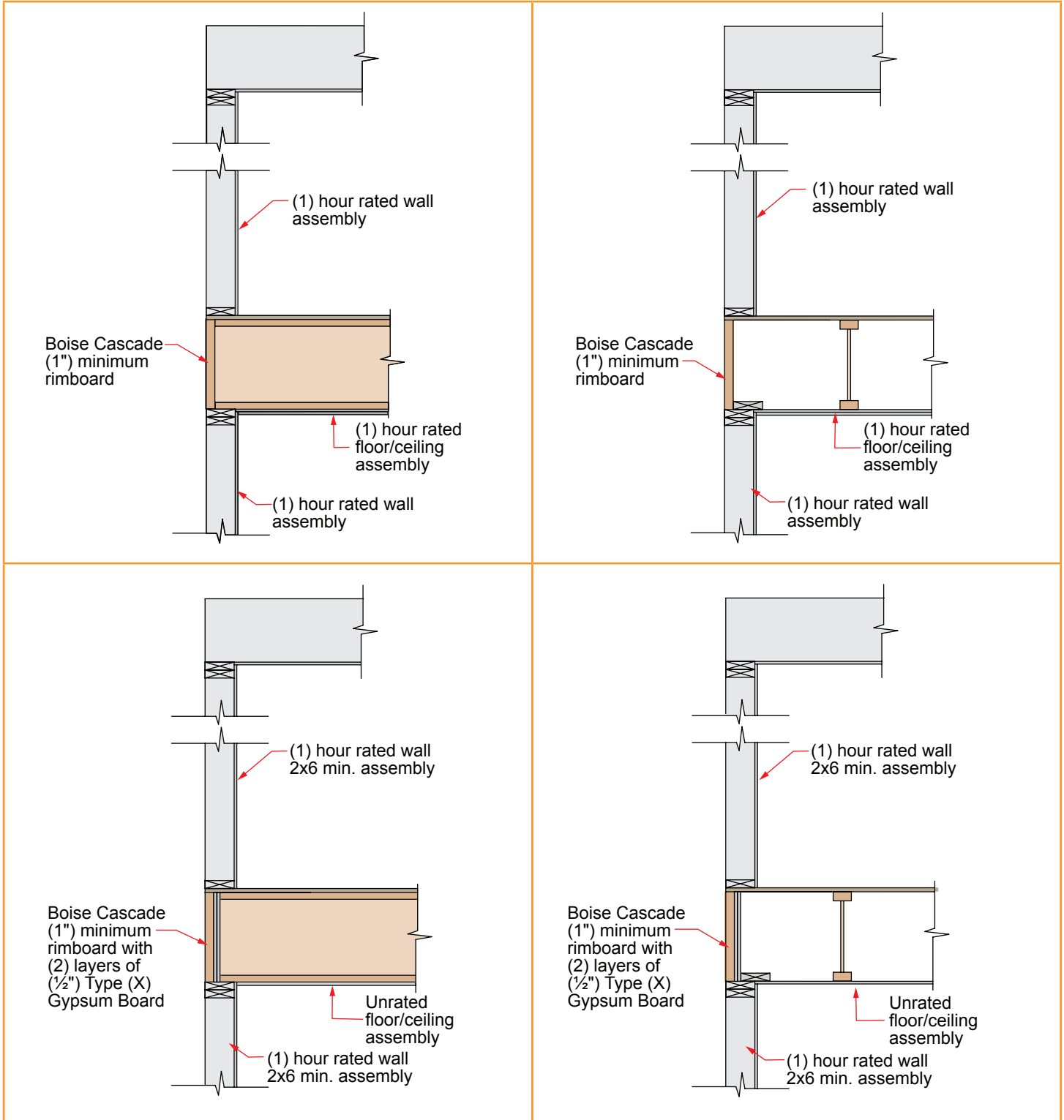

### Notes:

- Rim assembly for fire from inside of structure.
- Gypsum wallboard shown on the ceiling is to protect the Rim Board only; it does not necessarily cause the floor assembly to be rated.
- Attach 1/2" Type X to Rim Board with 1 1/2" Type W drywall screws spaced 12" o.c.
- Attach 5/8" Type X to Rim Board with 2" Type W drywall screws spaced 12" o.c.
- Provide minimum 1 3/4" bearing for I-Joist.
- Use only fire rated gypsum wallboard. Type C may be substituted for Type X.
- Rim Board and gypsum wallboard thickness are shown as minimums. Thicker Rim Board and gypsum wall board may be substituted.
- Rim board needs to be sized for vertical and lateral load.
- Details per APA PR-S201 RB1. Compliance of the fire-resistance rated construction assemblies with applicable building code is the responsibility of the design professional of record and/or authority having jurisdiction.

## End Wall Application

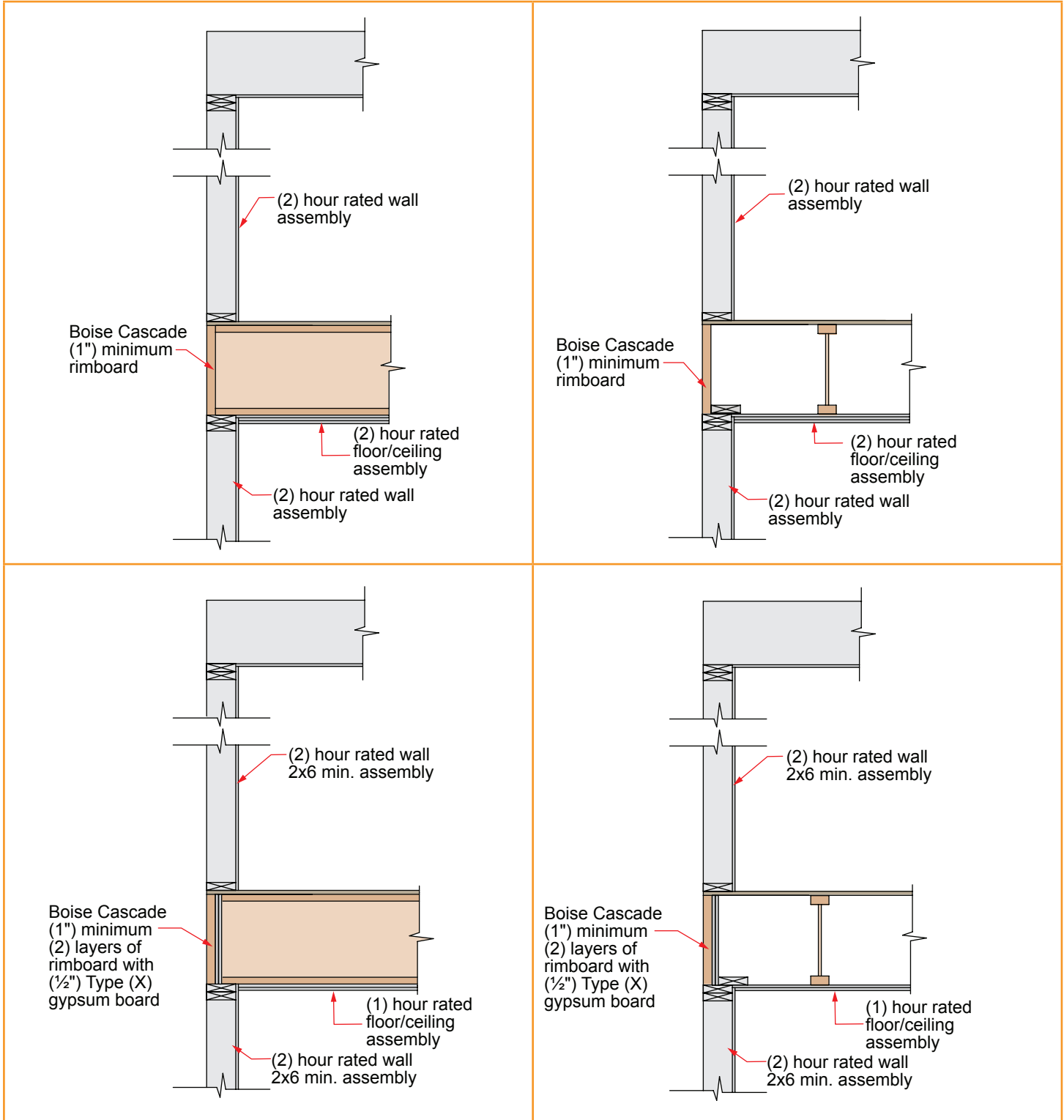

## Notes:

- Rim assembly for fire from inside of structure.
- Gypsum wallboard shown on the ceiling is to protect the Rim Board only; it does not necessarily cause the floor assembly to be rated.
- Attach 1/2" Type X to Rim Board with 1 1/2" Type W drywall screws spaced 12" o.c.
- Attach 5/8" Type X to Rim Board with 2" Type W drywall screws spaced 12" o.c.
- Provide minimum 1 3/4" bearing for I-Joist.

- Use only fire rated gypsum wallboard. Type C may be substituted for Type X.
- Rim Board and gypsum wallboard thickness are shown as minimums. Thicker Rim Board and gypsum wall board may be substituted.
- Rim board needs to be sized for vertical and lateral load.
- Details per APA PR-S201 RB1. Compliance of the fire-resistance rated construction assemblies with applicable building code is the responsibility of the design professional of record and/or authority having jurisdiction.



## Interior Single Wall Application

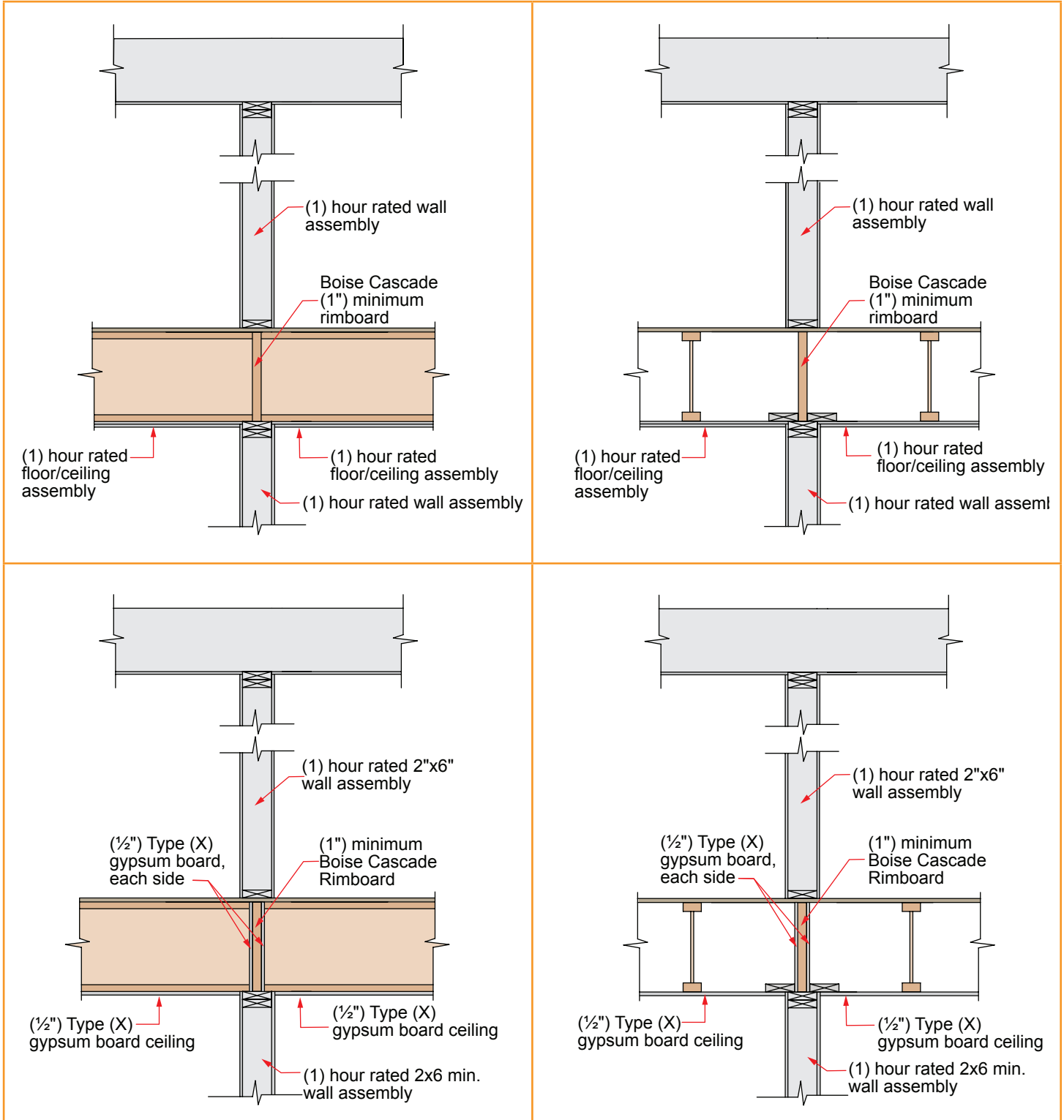

### Notes:

- Rim assembly for fire from either side of wall.
- Gypsum wallboard shown on the ceiling is to protect the Rim Board only; it does not necessarily cause the floor assembly to be rated.
- Attach 1/2" Type X to Rim Board with 1 1/2" Type W drywall screws spaced 12" o.c.
- Attach 5/8" Type X to Rim Board with 2" Type W drywall screws spaced 12" o.c.
- Provide minimum 1 3/4" bearing for I-Joist.

- Use only fire rated gypsum wallboard. Type C may be substituted for Type X.
- Rim Board and gypsum wallboard thickness are shown as minimums. Thicker Rim Board and gypsum wall board may be substituted.
- When two layers of gypsum wallboard are used, I-joint end nails shall be 16d box nails.
- Rim board needs to be sized for vertical and lateral load.
- Details per APA PR-S201 RB2. Compliance of the fire-resistance rated construction assemblies with applicable building code is the responsibility of the design professional of record and/or authority having jurisdiction.

## Interior Double Wall Application

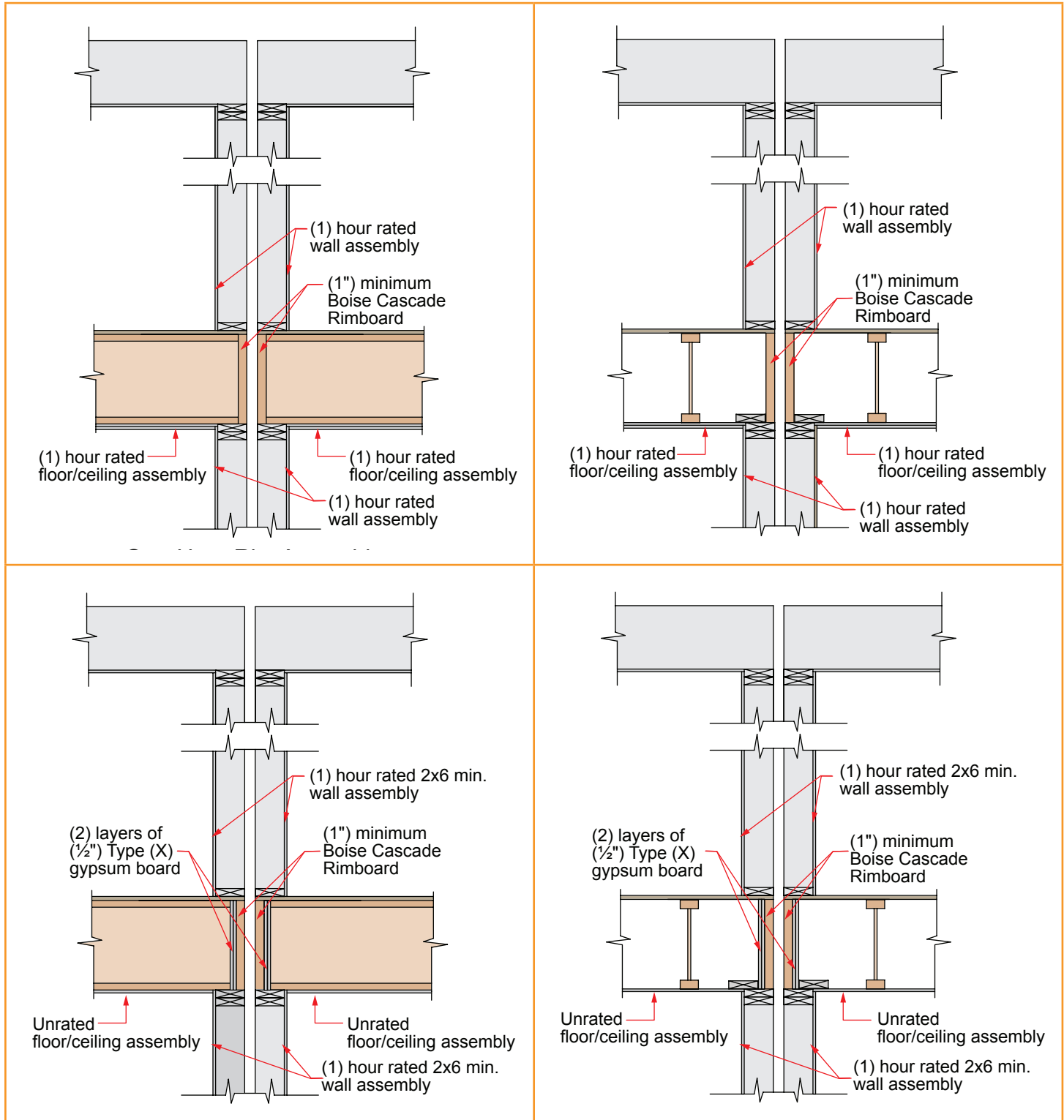

## Notes:

- Rim assembly for fire from either side of wall.
- Gypsum wallboard shown on the ceiling is to protect the Rim Board only; it does not necessarily cause the floor assembly to be rated.
- Attach 1/2" Type X to Rim Board with 1 1/2" Type W drywall screws spaced 12" o.c.
- Attach 5/8" Type X to Rim Board with 2" Type W drywall screws spaced 12" o.c.
- Provide minimum 1 3/4" bearing for I-Joist.

- Use only fire rated gypsum wallboard. Type C may be substituted for Type X.
- Rim Board and gypsum wallboard thickness are shown as minimums. Thicker Rim Board and gypsum wall board may be substituted.
- When two layers of gypsum wallboard are used, I-joint end nails shall be 16d box nails.
- Rim board needs to be sized for vertical and lateral load.
- Details per APA PR-S201 RB3. Compliance of the fire-resistance rated construction assemblies with applicable building code is the responsibility of the design professional of record and/or authority having jurisdiction.

## Interior Double Wall Application

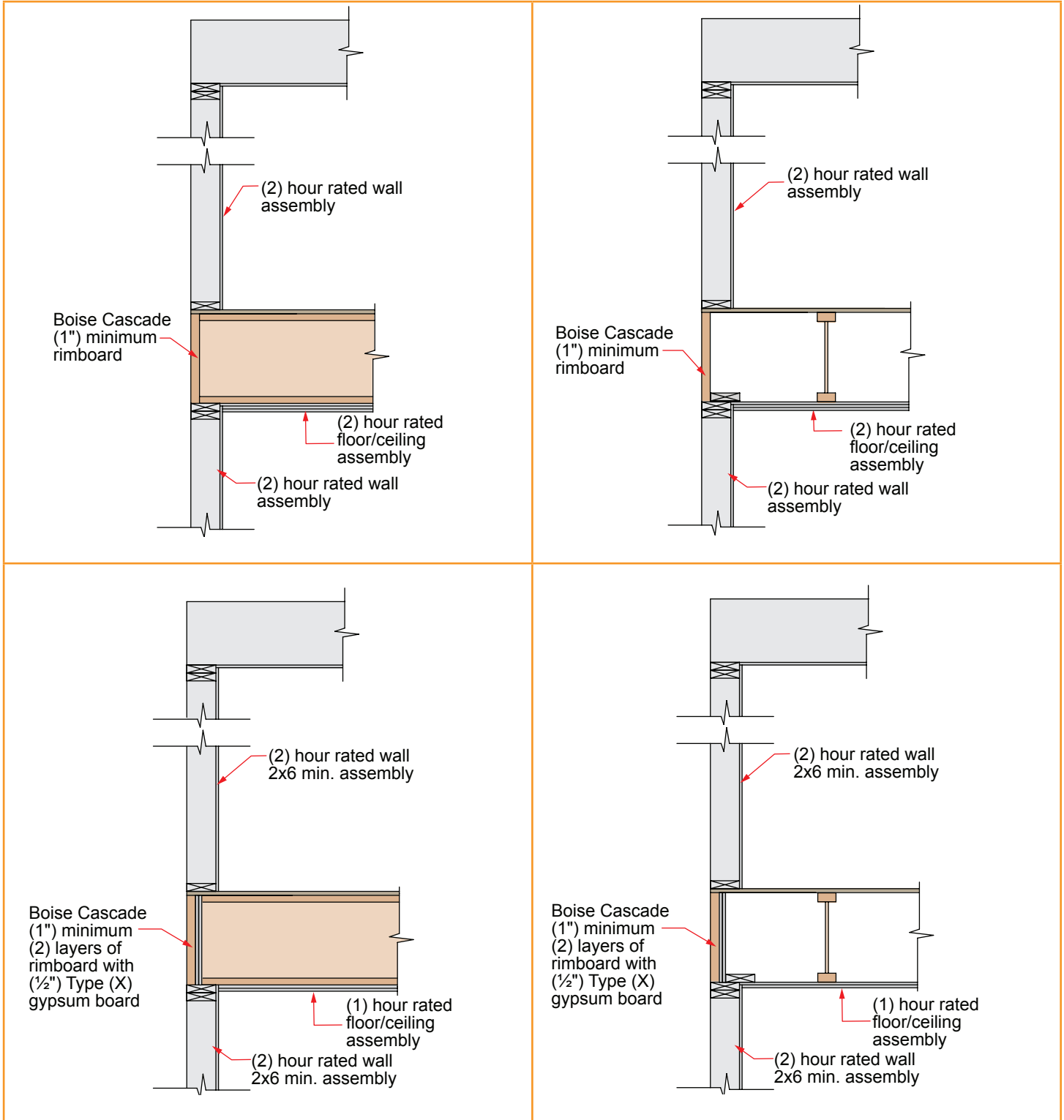

### Notes:

- Rim assembly for fire from either side of wall.
- Gypsum wallboard shown on the ceiling is to protect the Rim Board only; it does not necessarily cause the floor assembly to be rated.
- Attach 1/2" Type X to Rim Board with 1 1/2" Type W drywall screws spaced 12" o.c.
- Attach 5/8" Type X to Rim Board with 2" Type W drywall screws spaced 12" o.c.
- Provide minimum 1 3/4" bearing for I-Joist.

- Use only fire rated gypsum wallboard. Type C may be substituted for Type X.
- Rim Board and gypsum wallboard thickness are shown as minimums. Thicker Rim Board and gypsum wall board may be substituted.
- When two layers of gypsum wallboard are used, I-joint end nails shall be 16d box nails.
- Rim board needs to be sized for vertical and lateral load.
- Details per APA PR-S201 RB3. Compliance of the fire-resistance rated construction assemblies with applicable building code is the responsibility of the design professional of record and/or authority having jurisdiction.

## Introduction

Sprinkler systems provide reliable and effective suppression against fire. Though typically used in commercial-type buildings, sprinkler systems are also being installed in residential construction. Consult with the local building official for further information on sprinkler requirements. The details shown on pages 20-23 refer to the proper connection of commercial sprinkler pipe to Boise Cascade I-Joists. Connections to VERSA-LAM® and BOISE GLULAM® beams are similar to those used with solid-sawn lumber. Sprinkler pipe may also be routed through webs of Boise Cascade I-Joists; please refer to the specific joist's hole chart on pages 24-25.

Brackets, fixtures, and hangers shown in the sprinkler attachment details are referenced to the National Fire Protection Association (NFPA), an international, non-profit organization who publishes fire code and standards recognized worldwide.

The following details may be used for residential sprinklers but it should be noted that residential systems typically use much lighter and smaller pipe. The 2" diameter and smaller pipes used in residential sprinkler systems may bear directly on the joist web when routed through web holes. Residential sprinkler attachment details are shown on page 23.

## Commercial Sprinkler Pipe Weights

The weight of water-filled sprinkler pipe shall be added to the dead load of the joist or beam design. The following tables provide weights of typical commercial sprinkler pipe.

## Water-Filled Sprinkler Pipe Weight

Schedule #40 Steel Pipe	
Pipe Size [diameter - in]	Total Weight [lb/ft]
1	2.1
1.5	3.6
2	5.1
2.5	7.9
3	10.8
3.5	13.4
4	16.3
5	23.3
6	31.5

Schedule #10 Steel Pipe	
Pipe Size [diameter - in]	Total Weight [lb/ft]
1.25	2.5
1.5	3.0
2	4.2
2.5	5.9
3	7.9
4	11.8
6	23.0

## Sprinkler Attachment Details FS01 -FS03

**FS01 Two Screw Ceiling Flange**

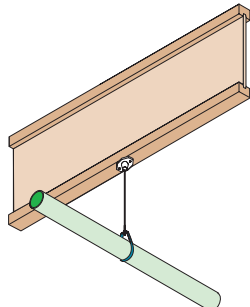

**FS01 Two Screw Ceiling Flange**  
2" Maximum Pipe Size

- Boise Cascade I-joist
- (2) screw ceiling plate 5/16" x 1 1/2" lag screws
- NFPA-approved fixture and bracket
- 2" max diameter pipe

- Attach the sprinkler apparatus as shown.
- Pre-drill pilot holes for lag screws.
- The sprinkler apparatus including the hanger, brackets, hanger rod, pipe, clamps, nuts, bolts, washers, lag screws, wood screws and installation shall be per the current provisions of the NFPA 13, 13D, 13R or the authority having jurisdiction.
- The design of the Boise Cascade I-Joist system shall also include the weight of the piping system and temporary loading.

**FS03 Side Beam Bracket**

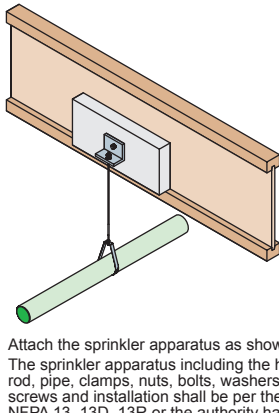

**FS03 Side Beam Bracket**  
2 1/2" Maximum Pipe Size

- Boise Cascade I-joist
- 2"x6"x18" block DF or SP #2 or btr
- 5/8" diameter machine bolt with nut and washer
- NFPA approved fixture and bracket
- 2 1/4" min
- 2 1/2" max diameter pipe

- Attach the sprinkler apparatus as shown.
- The sprinkler apparatus including the hanger, brackets, hanger rod, pipe, clamps, nuts, bolts, washers, lag screws, wood screws and installation shall be per the current provisions of NFPA 13, 13D, 13R or the authority having jurisdiction.
- The design of the Boise Cascade I-joist system shall also include the weight of the piping system and temporary loading.

FS04

## Eye Rod Hanger

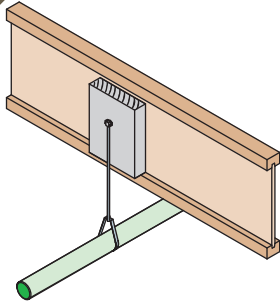

### FS04 Eye Rod Hanger

3 1/2" Maximum Pipe Size

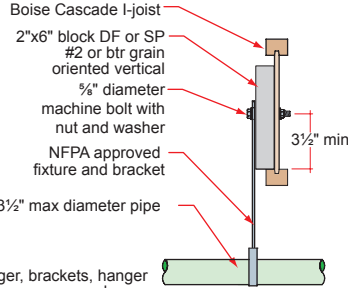

- Attach the sprinkler apparatus as shown.
- The sprinkler apparatus including the hanger, brackets, hanger rod, pipe, clamps, nuts, bolts, washers, lag screws, wood screws and installation shall be per the current provisions of NFPA 13, 13D, 13R or the authority having jurisdiction.
- The design of the Boise Cascade I-joist system shall also include the weight of the piping system and temporary loading.

FS06

## Eye Rod Hanger

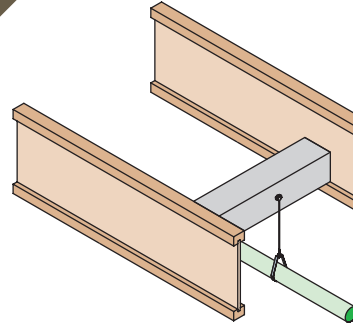

### FS06 Eye Rod Hanger

3 1/2" Maximum Pipe Size

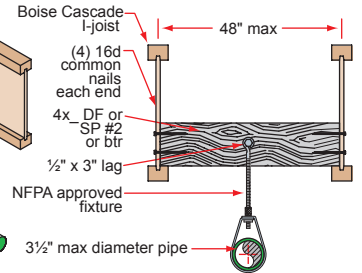

- Attach the sprinkler apparatus as shown.
- The sprinkler apparatus including the hanger, brackets, hanger rod, pipe, clamps, nuts, bolts, washers, lag screws, wood screws and installation shall be per the current provisions of NFPA 13, 13D, 13R or the authority having jurisdiction.
- The design of the Boise Cascade I-joist system shall also include the weight of the piping system and temporary loading.
- Pre-drill pilot hole for lag screw, allow for proper clearance from the lag to the bottom of the blocking. 2 1/2" for branch lines and 3" for main lines.

FS07

## I-Joist Hanger

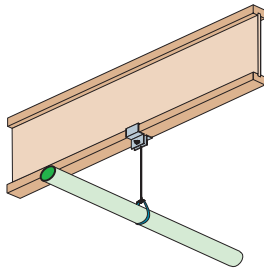

### FS07 I-Joist Hanger

4" Maximum Pipe Size

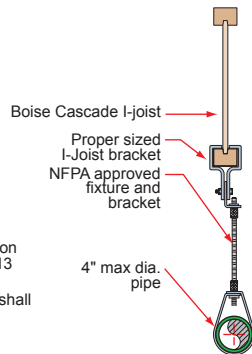

- Attach the sprinkler apparatus as shown.
- The sprinkler apparatus including the hanger, brackets, hanger rod, pipe, clamps, nuts, bolts, washers, lag screws, wood screws and installation shall be per the current provisions of the NFPA 13, 13D, 13R or the authority having jurisdiction.
- The design of the Boise Cascade I-joist system shall also include the weight of the piping system and temporary loading.

FS08

## U Hanger

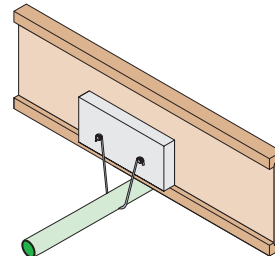

### FS08 U Hanger

4" Maximum Pipe Size

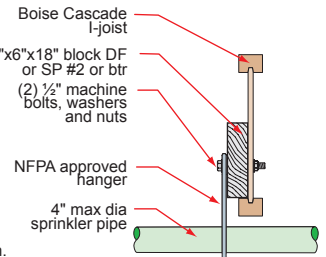

- Attach the sprinkler apparatus as shown.
- The sprinkler apparatus including the hanger, brackets, hanger rod, pipe, clamps, nuts, bolts, washers, lag screws, wood screws and installation shall be per the current provisions of the NFPA 13, 13D, 13R or the authority having jurisdiction.
- The design of the Boise Cascade I-joist system shall also include the weight of the piping system and temporary loading.

FS09

## Inverted U Hanger

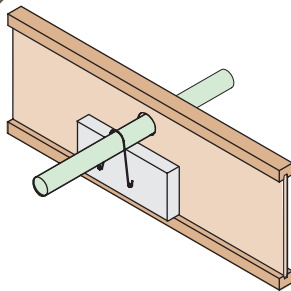

### FS09 Inverted U Hanger

4" Maximum Pipe Size

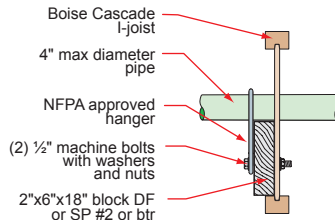

- Attach the sprinkler apparatus as shown.
- The sprinkler apparatus including the hanger, brackets, hanger rod, pipe, clamps, nuts, bolts, washers, lag screws, wood screws and installation shall be per the current provisions of the NFPA 13, 13D, 13R or the authority having jurisdiction.
- The design of the Boise Cascade I-joist system shall also include the weight of the piping system and temporary loading.

FS11

## U Hanger

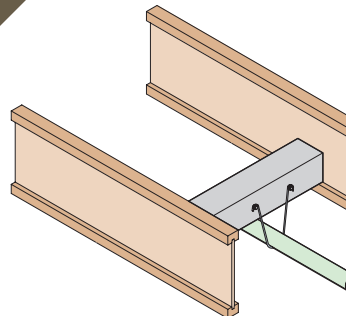

### FS11 U Hanger

4" Maximum Pipe Size

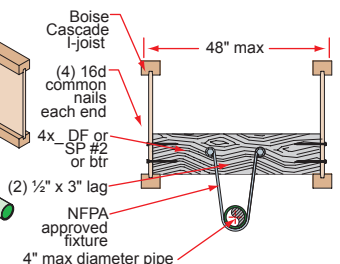

- Attach the sprinkler apparatus as shown.
- The sprinkler apparatus including the hanger, brackets, hanger rod, pipe, clamps, nuts, bolts, washers, lag screws, wood screws and installation shall be per the current provisions of the NFPA 13, 13D, 13R or the authority having jurisdiction.
- The design of the Boise Cascade I-joist system shall also include the weight of the piping system and temporary loading.
- Pre-drill pilot hole for lag screw, allow for proper clearance from the lag to the bottom of the blocking. 2 1/2" for branch lines and 3" for main lines.

**FS12 U Hanger**

**FS12 Inverted U Hanger**  
4" Maximum Pipe Size

- Attach the sprinkler apparatus as shown.
- The sprinkler apparatus including the hanger, brackets, hanger rod, pipe, clamps, nuts, bolts, washers, lag screws, wood screws and installation shall be per the current provisions of the NFPA 13, 13D, 13R or the authority having jurisdiction.
- The design of the Boise Cascade I-joist system shall also include the weight of the piping system and temporary loading.
- Pre-drill pilot hole for lag screw, allow for proper clearance from the lag to the bottom of the blocking, 2½" for branch lines and 3" for main lines.

**FS13 Pipe Strap**

**FS13 Pipe Strap**  
4" Maximum Pipe Size

- Attach the sprinkler apparatus as shown.
- The sprinkler apparatus including the hanger, brackets, hanger rod, pipe, clamps, nuts, bolts, washers, lag screws, wood screws and installation shall be per the current provisions of the NFPA 13, 13D, 13R or the authority having jurisdiction.
- The design of the Boise Cascade I-joist system shall also include the weight of the piping system and temporary loading.
- Pre-drill pilot hole for lag screw, allow for proper clearance from the lag to the bottom of the blocking, 2½" for branch lines and 3" for main lines.

**FS14 U Hanger**

**FS14 U Hanger**  
6" Maximum Pipe Size

- Attach the sprinkler apparatus as shown.
- The sprinkler apparatus including the hanger, brackets, hanger rod, pipe, clamps, nuts, bolts, washers, lag screws, wood screws and installation shall be per the current provisions of the NFPA 13, 13D, 13R or the authority having jurisdiction.
- The design of the Boise Cascade I-joist system shall also include the weight of the piping system and temporary loading.
- Pre-drill pilot hole for lag screw, allow for proper clearance from the lag to the bottom of the blocking, 2½" for branch lines and 3" for main lines.

**FS15 Inverted U Hanger**

**FS15 Inverted U Hanger**  
6" Maximum Pipe Size

- Attach the sprinkler apparatus as shown.
- The sprinkler apparatus including the hanger, brackets, hanger rod, pipe, clamps, nuts, bolts, washers, lag screws, wood screws and installation shall be per the current provisions of the NFPA 13, 13D, 13R or the authority having jurisdiction.
- The design of the Boise Cascade I-joist system shall also include the weight of the piping system and temporary loading.
- Pre-drill pilot hole for lag screw, allow for proper clearance from the lag to the bottom of the blocking, 2½" for branch lines and 3" for main lines.

**FS16 Inverted U Hanger**

**FS16 Pipe Strap**  
6" Maximum Pipe Size

- Attach the sprinkler apparatus as shown.
- The sprinkler apparatus including the hanger, brackets, hanger rod, pipe, clamps, nuts, bolts, washers, lag screws, wood screws and installation shall be per the current provisions of the NFPA 13, 13D, 13R or the authority having jurisdiction.
- The design of the Boise Cascade I-joist system shall also include the weight of the piping system and temporary loading.
- Pre-drill pilot hole for lag screw, allow for proper clearance from the lag to the bottom of the blocking, 2½" for branch lines and 3" for main lines.

**FS17 Seismic Bracing**

**FS17 Seismic Bracing Detail for Forces Parallel to Boise Cascade I-joists**

- Glue all contact surfaces with floor adhesive.
- Allowable loads shown represent only the capacity of the Boise Cascade I-joists, for sprinkler hanger apparatus capacities and connections, consult manufacturer or applicable version of NFPA 13.

Allowable Horizontal Seismic Forces (lbs.)		
Angle to Vertical	a	
30°	45°	60°
440	620	760

Section A-A

**FS18 Seismic Bracing**

**Seismic Bracing Detail for Forces Parallel or Perpendicular to Boise Cascade I-Joists for Pipe Bracing**

1) Glue all contact surfaces with floor adhesive.  
2) Allowable loads shown represent only the capacity of the Boise Cascade I-Joists, for sprinkler hanger apparatus capacities and connections consult manufacture or applicable version of NFPA 13.

**Allowable Horizontal Seismic Forces (lbs.)**

Angle To Vertical	a
30°	600
45°	600
60°	390

**FS19 Blocking Attachment to Joist**

**Blocking Attachment to Joist Hanger Attachment Varies**  
6" Maximum Pipe Size

- Attach the sprinkler apparatus as shown.
- The sprinkler apparatus including the hanger, brackets, hanger rod, pipe, clamps, nuts, bolts, washers, lag screws, wood screws and installation shall be per the current provisions of the NFPA 13, 13D, 13R or the authority having jurisdiction.
- The design of the Boise Cascade I-joist system shall also include the weight of the piping system and temporary loading.
- Pre-drill pilot hole for lag screw, allow for proper clearance from the lag to the bottom of the blocking.

For additional Boise Cascade I-Joist fire sprinkler attachment details, please contact Boise Cascade EWP engineering.

## Residential Sprinkler Details

**FS20 Residential Construction Stand-off Hanger for CPVC Pipe**

**Residential Construction Stand-off Hanger for CPVC Pipe**

Install fire sprinkler system per current edition of NFPA 13

**FS21 Residential Construction Perpendicular to Joists for CPVC Pipe**

**Residential Construction Perpendicular to Joists for CPVC Pipe**

Install fire sprinkler system per current edition of NFPA 13

# BCI® Joist Hole Location & Sizing

BCI® Joists are manufactured with 1 1/2" round perforated knockouts in the web at approximately 12" on center

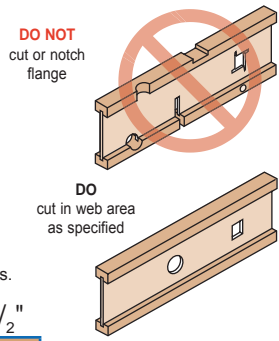
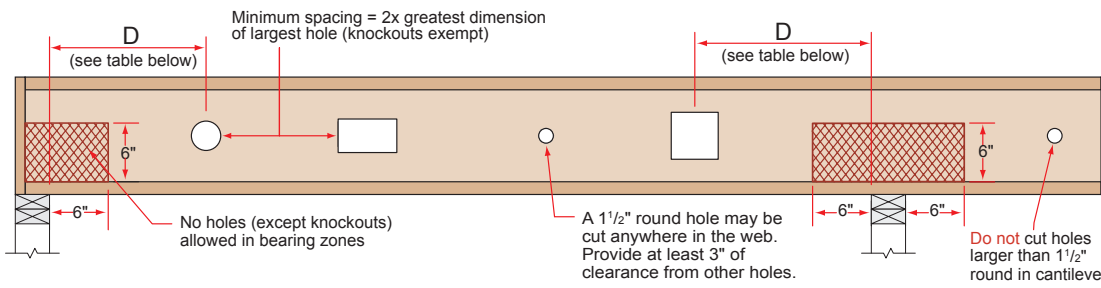

Minimum distance from support, listed in table below, is required for all holes greater than 1 1/2"

BCI® JOISTS ONLY - MINIMUM DISTANCE (D) FROM ANY SUPPORT TO THE CENTERLINE OF THE HOLE																
Round Hole Diameter [in]		2	3	4	5	6	7	8	8 7/8	10	11	12	13	14	15	
Rectangular Hole Side [in]		-	-	-	3	5	7	-	-	-	-	-	-	-	-	
Any 9 1/2" Joist	Span [ft]	8	1'-0"	1'-1"	1'-8"	2'-4"	2'-11"	3'-7"								
		12	1'-0"	1'-7"	2'-7"	3'-6"	4'-5"	5'-4"								
		16	1'-0"	2'-2"	3'-5"	4'-8"	5'-11"	7'-2"								
Any 11 7/8" Joist	Span [ft]	8	1'-0"	1'-1"	1'-6"	2'-0"	2'-5"	2'-11"	3'-5"	3'-10"						
		12	1'-0"	1'-7"	2'-3"	3'-0"	3'-8"	4'-5"	5'-1"	5'-9"						
		16	1'-2"	2'-1"	3'-0"	4'-0"	4'-11"	5'-10"	6'-10"	7'-8"						
20	1'-5"	2'-7"	3'-10"	5'-0"	6'-2"	7'-4"	8'-6"	9'-7"								
Any 14" Joist	Span [ft]	8	1'-0"	1'-1"	1'-2"	1'-2"	1'-6"	1'-11"	2'-4"	2'-9"	3'-3"	3'-8"				
		12	1'-0"	1'-1"	1'-2"	1'-7"	2'-3"	2'-11"	3'-6"	4'-1"	4'-10"	5'-6"				
		16	1'-0"	1'-1"	1'-3"	2'-2"	3'-0"	3'-10"	4'-9"	5'-6"	6'-6"	7'-4"				
20	1'-0"	1'-1"	1'-7"	2'-8"	3'-9"	4'-10"	5'-11"	6'-10"	8'-1"	9'-2"						
24	1'-0"	1'-1"	1'-11"	3'-3"	4'-6"	5'-10"	7'-1"	8'-3"	9'-9"	11'-0"						
Any 16" Joist	Span [ft]	8	1'-0"	1'-1"	1'-2"	1'-2"	1'-3"	1'-3"	1'-7"	1'-11"	2'-4"	2'-9"	3'-2"	3'-7"		
		12	1'-0"	1'-1"	1'-2"	1'-2"	1'-3"	1'-9"	2'-4"	2'-11"	3'-7"	4'-2"	4'-9"	5'-4"		
		16	1'-0"	1'-1"	1'-2"	1'-2"	1'-7"	2'-5"	3'-2"	3'-10"	4'-9"	5'-7"	6'-4"	7'-2"		
20	1'-0"	1'-1"	1'-2"	1'-2"	2'-0"	3'-0"	4'-0"	4'-10"	5'-11"	6'-11"	7'-11"	8'-11"				
24	1'-0"	1'-1"	1'-2"	1'-3"	2'-5"	3'-7"	4'-9"	5'-10"	7'-2"	8'-4"	9'-6"	10'-9"				
18" BCI® 90 2.0 Joist	Span [ft]	12	1'-0"	1'-1"	1'-2"	1'-2"	1'-5"	1'-11"	2'-4"	2'-9"	3'-3"	3'-9"	4'-2"	4'-8"	5'-1"	5'-7"
		16	1'-0"	1'-1"	1'-2"	1'-4"	1'-11"	2'-7"	3'-2"	3'-8"	4'-5"	5'-0"	5'-7"	6'-3"	6'-10"	7'-5"
		20	1'-0"	1'-1"	1'-2"	1'-8"	2'-5"	3'-3"	4'-0"	4'-8"	5'-6"	6'-3"	7'-0"	7'-9"	8'-7"	9'-4"
24	1'-0"	1'-1"	1'-2"	2'-0"	2'-11"	3'-10"	4'-9"	5'-7"	6'-7"	7'-6"	8'-5"	9'-4"	10'-3"	11'-2"		
28	1'-0"	1'-1"	1'-4"	2'-5"	3'-5"	4'-6"	5'-7"	6'-6"	7'-9"	8'-9"	9'-10"	10'-11"	12'-0"	13'-1"		
20" BCI® 90 2.0 Joist	Span [ft]	12	1'-0"	1'-1"	1'-2"	1'-2"	1'-3"	1'-6"	1'-11"	2'-3"	2'-9"	3'-2"	3'-7"	3'-11"	4'-4"	4'-9"
		16	1'-0"	1'-1"	1'-2"	1'-2"	1'-6"	2'-1"	2'-7"	3'-1"	3'-8"	4'-3"	4'-9"	5'-3"	5'-10"	6'-4"
		20	1'-0"	1'-1"	1'-2"	1'-3"	1'-11"	2'-7"	3'-3"	3'-10"	4'-7"	5'-3"	5'-11"	6'-7"	7'-4"	8'-0"
24	1'-0"	1'-1"	1'-2"	1'-6"	2'-4"	3'-1"	3'-11"	4'-7"	5'-6"	6'-4"	7'-2"	7'-11"	8'-9"	9'-7"		
28	1'-0"	1'-1"	1'-2"	1'-9"	2'-8"	3'-8"	4'-7"	5'-5"	6'-6"	7'-5"	8'-4"	9'-3"	10'-3"	11'-2"		

- Select a table row based on joist depth and the actual joist span rounded up to the nearest table span. Scan across the row to the column headed by the appropriate round hole diameter or rectangular hole side. Use the longest side of a rectangular hole. The table value is the closest that the centerline of the hole may be to the centerline of the nearest support.
- The entire web may be cut out. **DO NOT** cut the flanges. Holes apply to either single or multiple joists in repetitive member conditions.
- For multiple holes, the amount of uncut web between holes must equal at least twice the diameter (or longest side) of the largest hole.
- 1 1/2" round knockouts in the web may be removed by using a short piece of metal pipe and hammer.
- Holes may be positioned vertically anywhere in the web. The joist may be set with the 1 1/2" knockout holes turned either up or down.
- This table was designed to apply to the design conditions covered by tables elsewhere in this publication. Use the BC CALC® software to check other hole sizes or holes under other design conditions. It may be possible to exceed the limitations of this table by analyzing a specific application with the BC CALC® software.



AJS® Joists are manufactured with 1½" round perforated knockouts in the web at approximately 12" on center

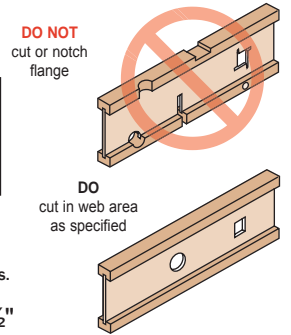
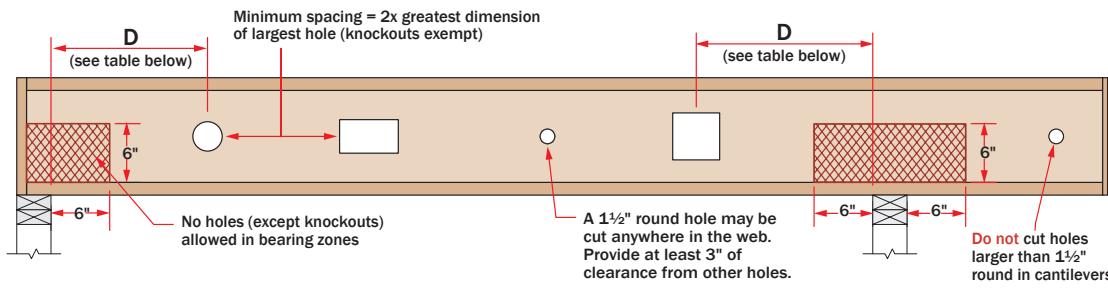

Minimum distance from support, listed in table below, is required for all holes greater than 1½"

AJS® JOISTS ONLY - MINIMUM DISTANCE (D) FROM ANY SUPPORT TO THE CENTERLINE OF THE HOLE																
Round Hole Diameter [in]		2	3	4	5	6	6½	7	8	8⅞	9	10	11	12	13	
Rectangular Hole Side [in]		-	-	2	4	6	6	-	-	-	-	-	-	-	-	
Any 9½" Joist	Span [ft]	8	2'-3"	2'-8"	3'-1"	3'-6"	4'-0"	4'-0"								
		12	3'-5"	4'-0"	4'-8"	5'-4"	6'-0"	6'-0"								
	Span [ft]	16	4'-6"	5'-5"	6'-3"	7'-1"	8'-0"	8'-0"								
		20	5'-11"	6'-10"	7'-10"	8'-11"	10'-0"	10'-0"								
Any 11⅞" Joist	Span [ft]	8	1'-7"	1'-11"	2'-4"	2'-8"	3'-0"	3'-3"	3'-5"	3'-9"	4'-0"					
		12	2'-5"	2'-11"	3'-6"	4'-0"	4'-7"	4'-10"	5'-1"	5'-8"	6'-0"					
	Span [ft]	16	3'-2"	3'-11"	4'-8"	5'-4"	6'-1"	6'-6"	6'-10"	7'-7"	8'-0"					
		20	4'-0"	4'-11"	5'-10"	6'-9"	7'-8"	8'-1"	8'-6"	9'-5"	10'-0"					
Any 14" Joist	Span [ft]	8	1'-1"	1'-5"	1'-9"	2'-1"	2'-5"	2'-7"	3'-0"	3'-4"	3'-8"	4'-0"				
		12	1'-8"	2'-2"	2'-8"	3'-1"	3'-7"	3'-10"	4'-1"	4'-7"	5'-0"	5'-6"	6'-0"			
	Span [ft]	16	2'-3"	2'-11"	3'-6"	4'-2"	4'-10"	5'-2"	5'-5"	6'-1"	6'-8"	6'-9"	7'-4"	8'-0"		
		20	2'-10"	3'-7"	4'-5"	5'-3"	6'-0"	6'-5"	6'-10"	7'-7"	8'-4"	8'-5"	9'-3"	10'-0"		
Any 16" Joist	Span [ft]	8	1'-0"	1'-1"	1'-4"	1'-7"	1'-11"	2'-1"	2'-2"	2'-6"	2'-9"	2'-9"	3'-1"	3'-4"	3'-8"	3'-11"
		12	1'-2"	1'-7"	2'-0"	2'-5"	2'-11"	3'-1"	3'-4"	3'-9"	4'-1"	4'-2"	4'-7"	5'-1"	5'-6"	5'-11"
	Span [ft]	16	1'-7"	2'-1"	2'-8"	3'-3"	3'-10"	4'-2"	4'-5"	5'-0"	5'-6"	5'-7"	6'-2"	6'-9"	7'-4"	7'-11"
		20	1'-11"	2'-8"	3'-5"	4'-1"	4'-10"	5'-2"	5'-7"	6'-3"	6'-11"	7'-0"	7'-9"	8'-5"	9'-2"	9'-11"
18" AJS® 25/30	Span [ft]	8	1'-0"	1'-1"	1'-2"	1'-2"	1'-4"	1'-6"	1'-8"	2'-0"	2'-4"	2'-4"	2'-9"	3'-1"	3'-5"	3'-10"
		12	1'-0"	1'-1"	1'-2"	1'-5"	2'-0"	2'-3"	2'-6"	3'-0"	3'-6"	3'-7"	4'-1"	4'-8"	5'-2"	5'-9"
	Span [ft]	16	1'-0"	1'-1"	1'-3"	1'-11"	2'-8"	3'-0"	3'-4"	4'-1"	4'-8"	4'-9"	5'-6"	6'-3"	6'-11"	7'-8"
		20	1'-0"	1'-1"	1'-6"	2'-5"	3'-4"	3'-9"	4'-2"	5'-1"	5'-10"	6'-0"	6'-11"	7'-9"	8'-8"	9'-7"
20" AJS® 25/30	Span [ft]	8	1'-0"	1'-1"	1'-10"	2'-11"	4'-0"	4'-6"	5'-1"	6'-1"	7'-1"	7'-2"	8'-3"	9'-4"	10'-5"	11'-6"
		12	1'-0"	1'-1"	1'-2"	1'-2"	1'-7"	1'-10"	2'-1"	2'-7"	3'-0"	3'-0"	3'-6"	4'-0"	4'-5"	4'-11"
	Span [ft]	16	1'-0"	1'-1"	1'-2"	1'-7"	2'-2"	2'-6"	2'-10"	3'-5"	4'-0"	4'-1"	4'-8"	5'-4"	5'-11"	6'-7"
		20	1'-0"	1'-1"	1'-2"	1'-11"	2'-9"	3'-1"	3'-6"	4'-4"	5'-0"	5'-1"	5'-10"	6'-8"	7'-5"	8'-3"
22" AJS® 25/30	Span [ft]	8	1'-0"	1'-1"	1'-5"	2'-4"	3'-3"	3'-9"	4'-3"	5'-2"	6'-0"	6'-1"	7'-1"	8'-0"	8'-11"	9'-10"
		12	1'-0"	1'-1"	1'-2"	1'-2"	1'-3"	1'-6"	1'-9"	2'-3"	2'-8"	2'-9"	3'-3"	3'-9"	4'-4"	4'-10"
	Span [ft]	14	1'-0"	1'-1"	1'-2"	1'-2"	1'-7"	1'-11"	2'-3"	2'-11"	3'-6"	3'-7"	4'-3"	4'-11"	5'-7"	6'-2"
		18	1'-0"	1'-1"	1'-2"	1'-2"	1'-11"	2'-4"	2'-9"	3'-7"	4'-3"	4'-4"	5'-2"	6'-0"	6'-9"	7'-7"
24" AJS® 25/30	Span [ft]	10	1'-0"	1'-1"	1'-2"	1'-2"	1'-3"	1'-3"	1'-3"	1'-7"	1'-11"	2'-0"	2'-4"	2'-8"	3'-1"	3'-5"
		14	1'-0"	1'-1"	1'-2"	1'-2"	1'-3"	1'-6"	1'-9"	2'-3"	2'-8"	2'-9"	3'-3"	3'-9"	4'-4"	4'-10"
	Span [ft]	18	1'-0"	1'-1"	1'-2"	1'-2"	1'-3"	1'-3"	1'-3"	1'-7"	2'-0"	2'-1"	2'-7"	3'-0"	3'-6"	4'-0"
		22	1'-0"	1'-1"	1'-2"	1'-2"	1'-3"	1'-3"	1'-5"	2'-1"	2'-7"	2'-8"	3'-3"	3'-11"	4'-6"	5'-2"

- Select a table row based on joist depth and the actual joist span rounded up to the nearest table span. Scan across the row to the column headed by the appropriate round hole diameter or rectangular hole side. Use the longest side of a rectangular hole. The table value is the closest that the centerline of the hole may be to the centerline of the nearest support.
- The entire web may be cut out. **DO NOT** cut the flanges. Holes apply to either single or multiple joists in repetitive member conditions.
- For multiple holes, the amount of uncut web between holes must equal at least twice the diameter (or longest side) of the largest hole.
- 1½" round knockouts in the web may be removed by using a short piece of metal pipe and hammer.
- Holes may be positioned vertically anywhere in the web. The joist may be set with the 1½" knockout holes turned either up or down.
- This table was designed to apply to the design conditions covered by tables elsewhere in this publication. Use the BC CALC® software to check other hole sizes or holes under other design conditions. It may be possible to exceed the limitations of this table by analyzing a specific application with the BC CALC® software.

VERSA-LAM® and BOISE GLULAM® beams and columns may be used as exposed members in fire resistance rated construction. The 2009 IBC references Chapter 16 of the National Design Specification for Wood Construction (NDS) for exposed wood member design procedures. Calculation procedures in Chapter 16 of the NDS ensure wood members are of sufficient size and capacity to carry the applied loads when adjusted for fire exposure. Adjustment of member carrying capacity is based upon the charring that occurs on the outside of a wood beam or column exposed to heat and flame.

Char is the residue created from the combustion of wood. Charring forms a self-insulating surface layer, which protects the wood fiber within from higher temperatures. Thus, the inner section of a beam or column retains its structural properties during a fire. VERSA-LAM® and BOISE GLULAM® beams have an equivalent char rate to that of commonly accepted solid sawn timber of approximately

1½ inches per hour. A char rate allows for the calculated fire resistance of a beam or column, since an uncharred cross-section can be estimated for a specified fire duration.

Chapter 16 of the NDS provides an effective char layer thickness for fire resistance calculations. The char layer thickness is based upon a char rate of 1½ inches per hour plus an additional thickness that accounts for heat damage at char/wood boundary. The remaining dimensions are then used to calculate section properties.

Fire Resistance Rating [hr]	Effective Char Layer Thickness $a_{char}$ [in]
1	1.8
1½	2.5
2	3.2

## Calculated Fire Resistance – VERSA-LAM®

VERSA-LAM® may be utilized in structures where component fire resistance is required due to its equivalent char rate to solid sawn lumber. The following is a floor beam design example following design procedures in chapter 16 of the NDS:

### Example 1: VERSA-LAM® Floor Beam

#### Problem:

A 7" x 14" VERSA-LAM® 2.0 3100 beam is specified in a floor application. Will the beam be adequate for a one hour fire resistance if exposed on three sides? Design loading is as follows:

- Span Length: 24'-0" (simple span)
- Floor Live Load: 50 psf, Floor Dead Load: 12 psf
- Tributary Area Width: 12'-0"

#### Solution:

Step 1: Determine allowable moment capacity after one hour fire exposure

Since the beam is exposed on three sides,  $b_{fire} = 3.4"$  and  $d_{fire} = 12.2"$ .

The resulting section properties are:

- Area ( $A_{fire}$ ) =  $b_{fire} * d_{fire} = 41.5 \text{ in}^2$
- Section Modulus ( $S_{fire}$ ) =  $b_{fire} * d_{fire}^2 / 6 = 84.3 \text{ in}^3$

Per NDS, the average bending strength may be used in fire design. Thus, the allowable bending stress is multiplied by a 2.85 factor. Since lateral support is assumed to be maintained during the fire, only the depth factor ( $C_f$ ) shall be applied. The depth factor is calculated using the original beam depth.

- Allowable Moment =  $2.85 * F'_b * C_f * S_{fire} = 2.85 * 3100 * (12/14)^{(1/9)} * 84.3 = 61,012 \text{ lb*ft}$

Step 2: Determine Actual Moment

- Actual Moment =  $w * L^2 / 8 = (50 + 12) * 12 * 24^2 / 8 = 53,568 \text{ lb*ft}$

Actual Moment < Allowable Moment: 5¼" x 14" VERSA-LAM® rated for one hour fire resistance

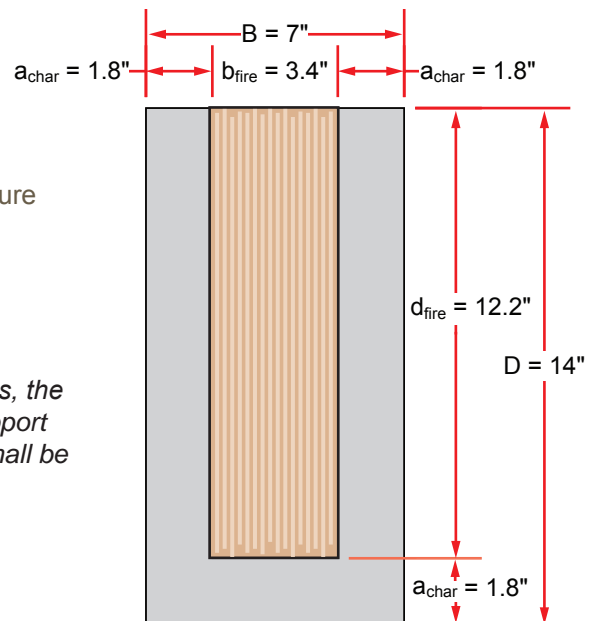

**Note:** ASCE 7 is the publication referenced in the IBC for determining building design loads. The commentary of ASCE 7 contains a section on design loading in extraordinary events. For an event such as a fire, the following load combination is given: 1.2\*dead load + (0.5\*live load or 0.2\*snow load). In the previous example, actual moment would have been considerably less using this load combination. The choice of a design load combination is the responsibility of the specific project's design professional of record.

## BOISE GLULAM® Fire Rated Lay-up

BOISE GLULAM® beams may be designed for projects where the fire resistance of individual components is necessary. Due to glulam layups - higher grade laminations are located in the top and bottom of the beam - a specific layup is required depending upon the fire duration required. For a 1 hour rated beam, an additional high grade tension lamination replaces a middle core lamination (see adjacent figure). 1½ and 2 hour fire-rated glulam beams may also be manufactured. For beams exposed to fire on all four sides, an equal number of high grade laminations are added to the top as well. All fire modified glulams are stamped with their corresponding fire duration rating. Since all fire-rated glulam beams are custom-order, please contact your local Boise Cascade representative for ordering.

Fire resistance can be calculated for non fire modified glulams as well. Without the bottom tension lamination, allowable design stresses can be calculated at 70% of the original design stresses. This reduction can only be applied to one hour fire ratings. Since the reduction is significant, the use of fire rated glulams typically provide a more efficient design.

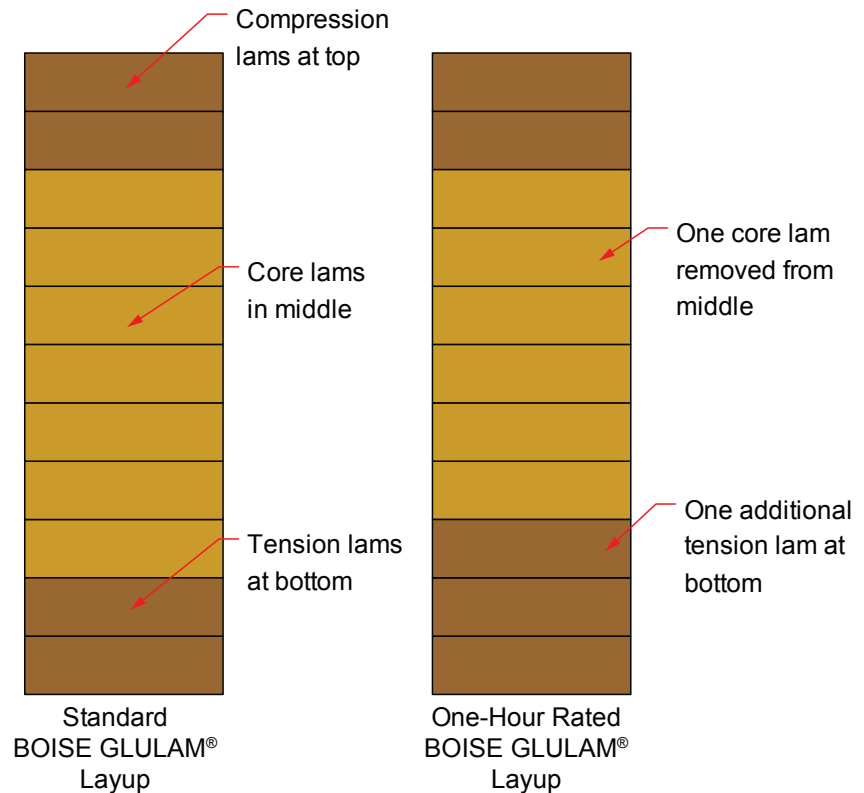

## Example 2: BOISE GLULAM® Ridge Beam

### Problem:

A 6¾" x 24" BOISE GLULAM 24F-V4/DF beam is specified in a ridge beam application. Will this beam with a fire rated layup be adequate for a one hour fire resistance if exposed on three sides? Design loading is as follows:

- Span Length: 30'-0" (simple span)
- Snow Load: 40 psf, Roof Dead Load: 15 psf
- Tributary Area Width: 16'-0"

### Solution:

Step 1: Determine allowable moment capacity after one hour fire exposure

Since the beam is exposed on three sides,  $b_{fire} = 3.15"$  and  $d_{fire} = 22.2"$ . The resulting section properties are:

- Area ( $A_{fire}$ ) =  $b_{fire} * d_{fire} = 69.9 \text{ in}^2$
- Section Modulus ( $S_{fire}$ ) =  $b_{fire} * d_{fire}^2 / 6 = 259 \text{ in}^3$

Lateral support is assumed to be maintained during the fire, thus only the volume factor ( $C_V$ ) shall be applied. The volume factor is calculated using the original beam dimensions.

- Volume Factor =  $(5.125/6.75)^{0.1} * (12/24)^{0.1} * (21/30)^{0.1} = 0.88$
- Allowable Moment =  $2.85 * F'_b * C_V * S_{fire} = 2.85 * 2400 * 0.88 * 259 = 129,300 \text{ lb*ft}$

Step 2: Determine Actual Moment

- Actual Moment =  $w * L^2 / 8 = (40 + 15) * 16 * 30^2 / 8 = 99,000 \text{ lb*ft}$

Actual Moment < Allowable Moment: 6 ¾" x 24" BOISE GLULAM 24F-V4/DF beam rated for one hour fire resistance

**Note:** If the BOISE GLULAM® was not a fire rated adjusted layup, the Allowable Moment =  $0.7 * 129,300 \text{ lb*ft} = 90,510 \text{ lb*ft}$ , which would not be structurally adequate for this application.



## Q: What is the Smoke Development Index?

A: The smoke development index is a measure of the concentration of smoke a material emits as it burns. VERSA-LAM® has a smoke index of 105, which is lower than most wood structural panels. A smoke development index of 450 is commonly used as a limiting value in building codes.

## Q: What is the difference between Type X and Type C gypsum board?

A: Fire-rated gypsum board is typically available in two separate types, X and C. When exposed to heat, water evaporates from the gypsum and the particles shrink. This causes the gypsum particles to lose their bond and the board disintegrates. In Type X gypsum board, glass fiber is mixed with gypsum during the manufacturing process. The glass fiber acts as reinforcement, increasing the board's structural capacity for a longer period of time during exposure to fire. Vermiculite ore is added with glass fiber in the production of Type C gypsum board. The vermiculite ore expands with an increase in temperature, in affect counteracting the shrinkage of the gypsum particles. Thus, Type C provides greater fire resistance than Type X. It is very important that the design professional of record specifies the correct type of fire-rated gypsum board per the floor/ceiling assemblies shown on pages 7-13.

## Q: Are the adhesives in EWP products fire rated?

A: The adhesives used in Boise Cascade EWP products have been extensively tested according to current American Society for Testing and Materials (ASTM) and Canadian Standards Association (CSA) specifications to ensure structural, moisture durability, and heat durability performance.

## Q: What is a flame spread rating?

A: A flame spread rating is used to assess the surface flammability of building materials and interior finish products by measuring the rate that flame travels across the surface of a material. The U.S. building codes specify three classifications of building areas, dependent upon the fire hazard severity. These classifications are dependent upon the fire severity in a particular building area. A specific material is allowed in an area if its flame spread rating meets the individual classification standard. Class I or A represents areas where the fire risk is most severe, for example an exitway for a public assembly area that does not have sprinklers. Plywood and lumber that are fire-retardant treated are allowed in this most severe classification. VERSA-LAM® qualifies in the Class II or B classification. Thus, VERSA-LAM® may be installed in areas within this classification, such as exit corridors in business, educational, multi-family and hotel structures. VERSA-LAM® may also be used in Class III or C areas, which include all residential areas and in specific rooms of most all other structures (excluding hospitals and institutions). Most all other wood products fall into this

category, including structural panels, solid-sawn lumber, Boise Cascade BCI® and AJS® Joists, Boise Rimboard and BOISE GLULAM® Beams. It should be noted that flame spread is only a surface measurement and can not be used to determine the fire duration of a structural component.

## Q: Are Boise Cascade EWP products available with a fire retardant treatment?

A: Boise Cascade does not manufacture any BCI®, AJS® or VERSA-LAM® with a fire retardant treatment and does not allow the products to be pressure-treated by a third-party. Fire-retardant treatments typically reduce the strength and stiffness of the wood. There are some topical treatments on the market for wood that claim to provide a Class A flame spread rating. Boise Cascade has not tested any of these products to substantiate any of the claims made by these treatments and the claims of flame spread rating for these treatments is the responsibility of the treatment manufacturer.

## Q: Do Boise Cascade fire assemblies have a UL® listing?

A: Underwriters Laboratories® is one of several testing laboratories in North America that are certified by the national building codes to perform floor/ceiling and wall assembly testing. For those assemblies, all certified laboratories conduct the fire testing per the same ASTM provisions. If a building official or designer requests a UL number, this publication containing the assembly in question with the corresponding code reference numbers may be submitted. A complete listing of Boise Cascade fire-endurance rated assemblies can be obtained from the APA – The Engineered Wood Association at the following web address:

[www.apawood.org/level\\_b.cfm?content=prd\\_rept\\_main](http://www.apawood.org/level_b.cfm?content=prd_rept_main) .

## Q: What is mineral fiber insulation and how is it specified?

A: Mineral fiber insulation is a fire resistive material composed principally of fibers manufactured from rock, slag, or glass, with or without binders. Mineral fiber insulation is typically used in one-hour floor ceiling assemblies that utilize a single layer of gypsum board (see details on pages 9-13). The mineral fiber insulation batts are basically a fire resistant substitute for the second layer of gypsum board, in order to maintain a one-hour fire rating. Mineral fiber insulation is specified in a thickness (inches) and density (pounds per cubic foot). Though the specified material dimensions should be followed in constructing assemblies, equivalent mineral fiber insulation may be substituted per approval of the project's design professional of record and Boise Cascade EWP Engineering. For example, if 2" thick - 3.5 pcf thick mineral wool is listed, a thicker but less dense product may be used if approved. An equivalent thickness for 2.8 pcf mineral wool would be 2.5" (equivalent thickness = 2" x (3.5 pcf / 2.8 pcf) = 2.5").





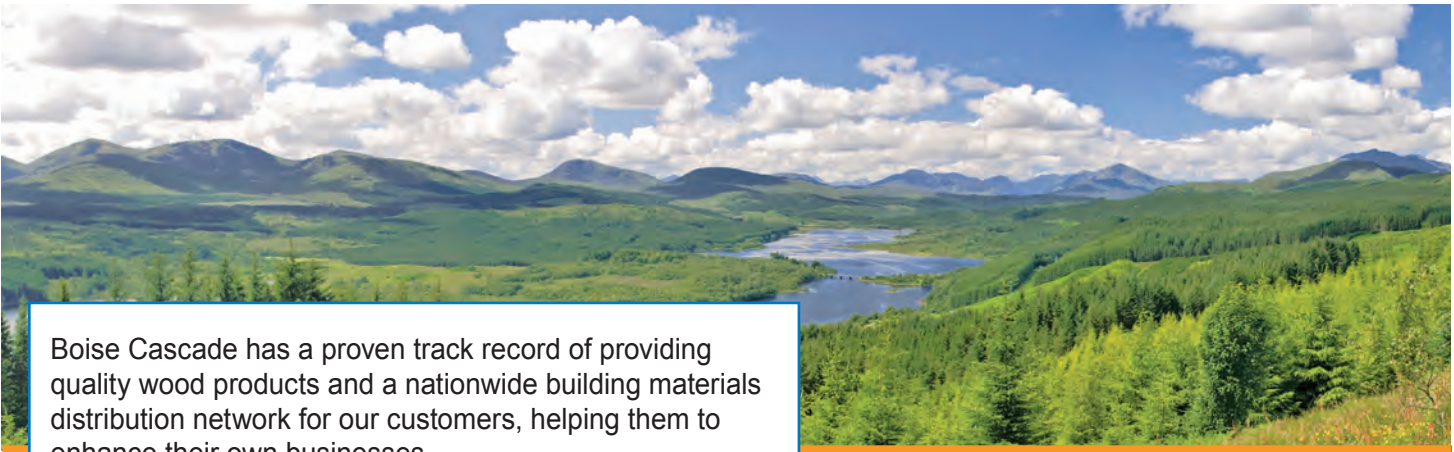

Boise Cascade has a proven track record of providing quality wood products and a nationwide building materials distribution network for our customers, helping them to enhance their own businesses.

Boise Cascade Engineered Wood Products build better homes with stronger, stiffer floors using only wood purchased in compliance with a number of green building programs. Take a moment to view our sustainability certification site at <http://www.bc.com/sustainability/certification.html> or view our green brochure at [http://www.bc.com/wood/ewp/Boise\\_EWP\\_Green.html](http://www.bc.com/wood/ewp/Boise_EWP_Green.html).

Boise Cascade Engineered Wood Products throughout North America can now be ordered FSC® Chain-of-Custody (COC) certified, enabling homebuilders to achieve LEED® points under U.S. Green Building Council® residential and commercial green building programs including LEED for Homes and LEED for New Construction. Boise Cascade Engineered Wood Products are available as PEFC® Chain-of-Custody certified, SFI® Chain-of-Custody certified and SFI Fiber-Sourcing certified, as well as NAHB Research Center Green Approved, enabling homebuilders to also obtain green building points through the National Green Building Standard.

## Lifetime Guaranteed Quality and Performance

Boise Cascade warrants its BCI® Joist, VERSA-LAM®, and ALLJOIST® products to comply with our specifications, to be free from defects in material and workmanship, and to meet or exceed our performance specifications for the normal and expected life of the structure when correctly stored, installed and used according to our Installation Guide.

If in doubt, ask!  
For the number of the closest  
Boise Cascade EWP  
distributor/support center, call  
★ 1-800-232-0788 ★



BOISE CASCADE, TREE-IN-A-CIRCLE, BCI, BC CALC, BC COLUMN, BC FRAMER, BC RIM BOARD, BOISE GLULAM, SIMPLE FRAMING SYSTEM, VERSA-LAM, VERSA-RIM, VERSA-STRAND, and VERSA-STUD are trademarks of Boise Cascade, L.L.C. or its affiliates.

For information about  
Boise Cascade Engineered Wood Products,  
including sales terms and conditions,  
warranties and disclaimers,  
visit our website at [www.BCewp.com](http://www.BCewp.com)

Your Dealer is:



**Boise Cascade**  
*Engineered Wood Products*

**Great products are only the beginning.®**

If no dealer is listed, call 1-800-232-0788

Copyright © Boise Cascade Wood Products, L.L.C. 2013  
EWP US FDIG09/05/2013