



**Boise Cascade**  
Engineered Wood Products

# VERSA-STUD® 1.7 2650 WALL GUIDE

for product manufactured in Alexandria [Lena], Louisiana



*Stronger  
and  
Stiffer  
for  
Tall Walls  
and  
High Wind  
Loads*

*Straighter  
for  
Cabinet  
and  
Tile Walls*

Better homes from better builders —  
by design . . .  
with **VERSA-STUD®** wall framing

VERSA-STUD 1.7 2650  
WALL GUIDE EAST  
11/07/2008 r 07/21/2011

# VERSA-STUD® 1.7 2650

## Engineered Studs for Tall Walls

**VERSA-STUD® 1.7 2650** laminated veneer lumber wall framing is engineered for the high quality builder who wants . . .

- Stronger walls to resist wind loads
- Stiffer walls for a solid feel
- Straight walls for a high quality finish



Long, continuous **VERSA-STUD® 1.7 2650** wall framing will provide superior strength, stiffness, and appearance in any tall wall application. **VERSA-STUD® 1.7 2650** wall framing provides more resistance to wind pressure than walls framed with dimension lumber and eliminates the hinge created by platform framing. 1 1/2" x 5 1/2" **VERSA-STUD® 1.7 2650** wall framing has 2.3 times more bending strength than No. 2 SPF 2x6 studs.

Building Code Approved  
for Both Prescriptive and  
Engineered Wall Stud Design

\* 9 1/4" and 11 1/4" depths may be available. Check with supplier or Boise Cascade EWP representative for availability.

Table of Contents

Product profile . . . . .	2	VERSA-STUD® & VERSA-LAM® Column Details . . . . .	12
Prescriptive Design . . . . .	3	VERSA-LAM® 1.7 2650 Exterior Wall Column Table . . . . .	13
Engineered Design Assumptions for Load Tables . . . . .	4	Connectors . . . . .	14
Wall Deflection . . . . .	5	Connectors / Allowable Holes and Notches . . . . .	15
Determining Wind Load . . . . .	6	Design Properties . . . . .	16
Wind Load Definitions . . . . .	7	VERSA-STUD® Wall Sheathing Nailing . . . . .	17
VERSA-STUD® & VERSA-LAM® Column Design Example . . . . .	8	BC COLUMN® Software . . . . .	18
Stud Load Tables - VERSA-STUD® 1.7 2650 1 1/2" x 3 1/2" . . . . .	9	Computer Software . . . . .	19
Stud Load Tables - VERSA-STUD® 1.7 2650 1 1/2" x 5 1/2" . . . . .	10	Information and Support, SFI, Lifetime Guarantee . . . . .	Back cover
Stud Load Tables - VERSA-STUD® 1.7 2650 1 1/2" x 7 1/4" . . . . .	11		

VERSA-STUD® may be used as wall studs in accordance with the prescriptive requirements in section 2308.9 of the IBC and section R602 of the IRC. The below table lists span and spacing limits for prescriptive stud design. Prescriptive design is valid for structures where the wind load does not exceed 110 mph (100 mph in hurricane-

prone regions), the ground snow load does not exceed 70 psf, dead loads on floors or roof do not exceed 20 psf, and several other provisions listed in both building codes. The building design professional of record shall determine whether the structure qualifies for prescriptive design.

Prescriptive Wall Stud Limits for Conventional Construction			
Wall Type	Stud Size	Stud Height	Max O.C. Spacing
Bearing wall supporting roof and ceiling only	1½" x 3½"	10'	24"
	1½" x 5½"	10'	24"
Bearing wall supporting one floor only	1½" x 3½"	10'	24"
	1½" x 5½"	10'	24"
Bearing wall supporting one floor, roof and ceiling	1½" x 3½"	10'	16"
	1½" x 5½"	10'	24"
Bearing wall supporting two floors, roof and ceiling	1½" x 3½"	10'	—
	1½" x 5½"	10'	16"
Non-bearing walls	1½" x 3½"	14'	24"
	1½" x 5½"	20'	24"



• Limits per IRC Table R602.3(5)

## Using VERSA-STUD® for Cabinet and Tile Walls

Dimension lumber can exceed 30% moisture content. Wood dries to a moisture content of 10-12% once the building is finished. Shrinkage and warping of 2x studs is a problem in walls where cabinets are hung or tile is installed. Though 2x studs cost less, added labor from shimming cabinets, straightening walls and drywall repairs can quickly add up. VERSA-STUDS® eliminate these issues, providing a straight and true wall every time.

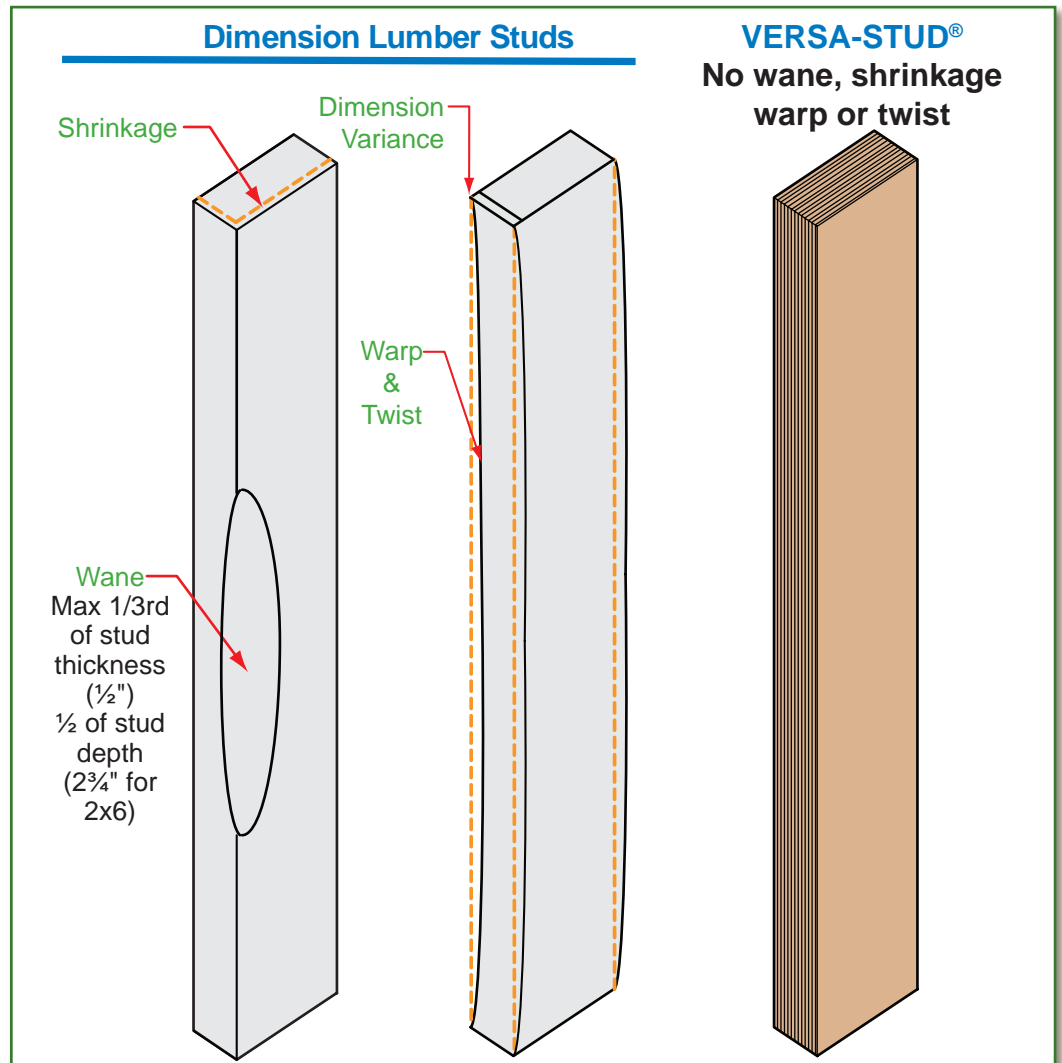

Load table values are based upon axial loads applied at the top of the stud and lateral wind loads perpendicular to the wall (out of plane loading). Lateral loads parallel to the wall (in-plane loading), caused by seismic and wind, shall be designed by the project's design professional of record.

Allowable loads based upon the design provisions of the National Design Specification for Wood Construction (NDS), 2005 edition.

Studs receive axial load concentrically through a double top plate and thus no eccentricity is assumed.

A buckling length coefficient  $K_e$  (based on the fixity of stud ends) is 1.0.

Load table values based upon assumption that stud walls have structural sheathing applied to one side or a combination of non-structural sheathing on the exterior side and gypsum wallboard on the interior side.

Blocking between studs required at a maximum spacing of 8'-0".

The repetitive member factor of 1.04 has been applied to the VERSA-STUD® allowable bending stress.

Wind load duration factor  $C_D = 1.6$ .

Maximum rough opening height of adjoining openings shall not exceed 84".

Double stud members and larger members shown in tables are assumed to be located between openings or at sides of openings. Single stud members shown in tables shall not be used between openings.

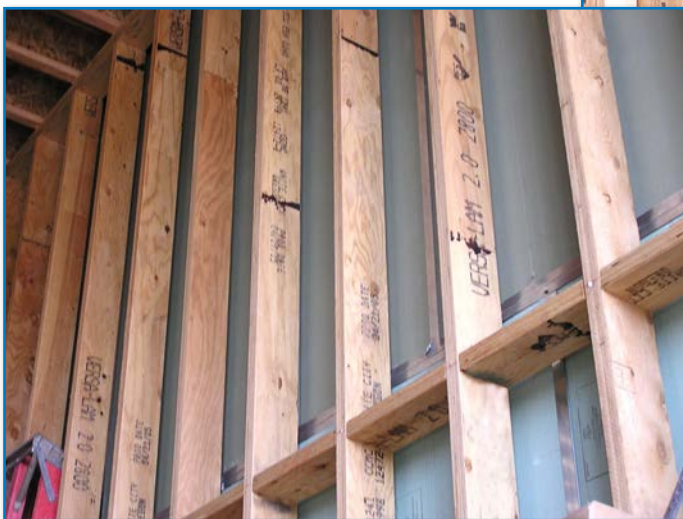

## Load Combinations

The allowable design loads shown in this guide are based upon load combination equations for allowable stress design (IBC 06 Section 1605.3.1). Specifically for wall applications:

1. roof dead load + roof live or snow load
2. roof dead load + 0.75 x (roof live or snow load + wind load)
3. 0.6 x dead load + wind load

Since the chances are extremely remote that the maximum roof live or snow load will be present at the same time as a maximum wind load, the IBC allows for a 25% reduction in both loads when applied simultaneously in load combination #2.

## Code References

When calculating deflection from wind, the design wind load is determined by multiplying the Components & Cladding pressure by 0.7 (IBC 06 Table 1604.3, footnote f & IRC 06 Table R301.7, footnote a).



Deflection of individual wall studs is calculated similar to that of joists and beams. The stud height, on-center spacing and stiffness determine the deflection from a design wind load. Below are the building code deflection limit provisions dependent upon the wall coverings.

Wall Type or Component	Max Deflection Limit	Corresponding Max Deflection for 20' wall height	Code Reference
Exterior Walls with plaster or stucco finish	L/360	0.67 in	IRC 06: Table R301.7
Exterior walls with brittle finishes (brick and stone veneer - see note below)	L/240	1.0 in	IBC 06: Table 1604.3 IRC 06: Table R301.7
Interior walls and partitions	L/180	1.33 in	IRC 06: Table R301.7
Mullions (members supporting windows or doors)	L/175	—	IRC 06: R613.9.3
Exterior walls with flexible finishes (lap, panel and metal sidings)	L/120	2.0 in	IBC 06: Table 1604.3 IRC 06: Table R301.7

Wall stud deflection may occur both into the structure (positive pressure) or out from the structure (negative pressure). Thus, the total amount of possible movement is actually almost twice the deflection value shown in the design tables (see detail below). As shown in the table above, using the code minimum L/120 limit for 20' stud height can result in a deflection of 2 inches. More restrictive deflection limits may be used, similar to Boise Cascade's Three and Four Star Floor Performance tables for BCI® Joists. The allowable load tables on pages 9-11 provide maximum loads for deflection limits ranging from L/360 to L/120. For applications where a tighter deflection limit is needed, the stud may be designed using the BC COLUMN™ software. As is the case with floors, the deflection of tall walls should be considered in the design phase of the project.

Deflection criteria is used to limit serviceability issues such as doors and windows binding, cracking of exterior and interior surface materials, perceived sounds due to wall movement, glass breaking, wall vibration and movement when pushed on. Wind produces pressure and suction loads on a wall producing deflection inward and outward. Vibration of walls can occur with high span/depth ratios much like a floor joist where depth equals the wall thickness. For further information on wall vibration, please contact Boise Cascade EWP Engineering.

In regards to brick veneer, though the IBC and IRC list a deflection limit of L/240, the Brick Industry Association (BIA) recommends designing studs to a deflection limit of L/600 to limit cracking of the veneer caused by excessive deflection. Such designs may be analyzed using BC COLUMN™ software.

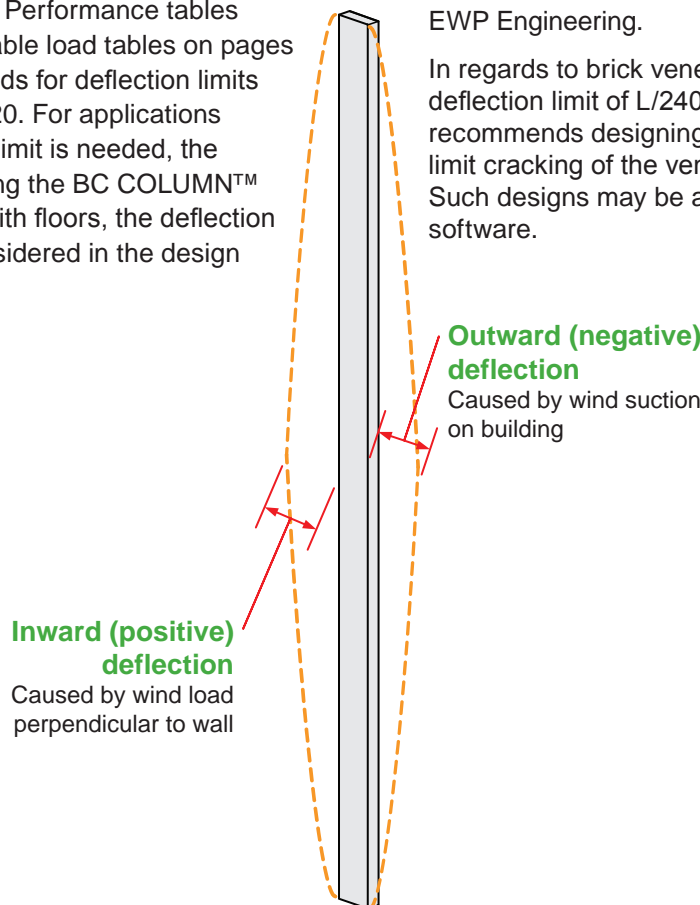

In some areas the design wind load, in units of psf [lb/ft<sup>2</sup>], is provided for residential construction by the local building code jurisdiction. For example, the State of Wisconsin Uniform Dwelling Code mandates a 20 psf design wind load. *Please refer to the local building code department for such information.*

For areas that do not provide a wind load or for non-residential projects, the wind load may be determined by using the basic wind speed, in units of mph or miles per hour. The wind speed is then converted into a design wind load by calculating all the necessary factors required by ASCE 7, per the IRC and IBC codes. These factors are dependent on the site location of the project and the dimensions of the structure. Typically, the project's design professional of record performs this analysis. The following is an overview of this procedure:

- Determine basic wind speed:** Contour maps are provided in the IRC & IBC. The majority of the inland U.S. has a wind speed of 90 mph. However, basic wind speeds up to 150 mph are required in coastal areas. In addition, special wind region areas exist where the wind speed is higher. Consult with the local building code jurisdiction for the site's design wind speed.
  - Determine the project's exposure category:** The exposure of the site will affect the wind load; wind pressure will be less within a subdivision versus a structure near a body of water. For wood-frame buildings, the three exposure categories are defined
- (see IRC 301.2.1.4 for complete definitions):
- Exposure B: Urban and suburban (subdivision) areas, forest land.
  - Exposure C: Open terrain with scattered obstructions less than 30 feet tall extending more than 1500 feet from the site in any direction.
  - Exposure D: Flat, unobstructed areas exposed to wind over open water (excluding shorelines in hurricane prone regions) for a distance of at least 1 mile.
- Determine the stud or column's effective wind area:** Calculated using the greater of  $L^2/3$  or the tributary area, see Effective Wind Area in Wind Load Definitions, page 7.
  - Determine remaining factors:**
    - Importance Factor: 1.0 for most structures, 1.15 for essential service buildings.
    - Topographical Factor: 1.0 for most structures, higher for buildings on hills or ridges.
  - Determine mean roof height:** The distance between grade and a midpoint height between the eave and ridge.
  - Go to the tables in ASCE 7 to determine the design wind load.** For a mean roof height of 33', importance factor = 1.0 and topographical factor = 1.0, the following table may be used:

Exposure Category	Effective Wind Area	Wind Design Load [psf]															
		85 mph		90 mph		100 mph		110 mph		120 mph		130 mph		140 mph		150 mph	
		Interior Zone	End Zone	Interior Zone	End Zone	Interior Zone	End Zone	Interior Zone	End Zone	Interior Zone	End Zone	Interior Zone	End Zone	Interior Zone	End Zone	Interior Zone	End Zone
B	<=10	14.5	17.9	16.2	20.1	20.1	24.8	24.3	30.0	28.9	35.6	33.9	41.8	39.3	48.5	45.1	55.7
	20	13.9	16.7	15.6	18.7	19.2	23.1	23.3	27.9	27.7	33.2	32.5	39.0	37.7	45.2	43.2	51.9
	50	13.1	15.1	14.7	16.9	18.1	20.9	21.6	25.3	26.1	30.1	30.6	35.3	35.5	40.9	40.8	47.0
	>=100	12.5	13.9	14.0	15.6	17.3	19.2	20.9	23.3	24.9	27.7	29.2	32.5	33.9	37.7	38.9	43.2
C	<=10	20.2	24.9	22.6	27.9	27.9	34.5	33.8	41.7	40.2	49.6	47.2	58.2	54.7	67.5	62.8	77.5
	20	19.3	23.2	21.7	26.0	26.8	32.1	32.4	38.9	38.5	46.3	45.2	54.3	52.4	63.0	60.2	72.3
	50	18.2	21.0	20.4	23.6	25.2	29.1	30.5	35.2	36.3	41.9	42.6	49.1	49.4	57.0	56.8	65.4
	>=100	17.4	19.3	19.5	21.7	24.1	26.8	29.1	32.4	34.6	38.5	40.7	45.2	47.2	52.4	54.1	60.2
D	<=10	23.8	29.4	26.7	32.9	32.9	40.6	39.8	49.2	47.4	58.5	55.6	68.7	64.5	79.6	74.1	91.4
	20	22.8	27.4	25.6	30.7	31.6	37.9	38.2	45.8	45.4	54.6	53.3	64.0	61.8	74.3	71.0	85.3
	50	21.5	24.8	24.1	27.8	29.7	34.3	36.0	41.5	42.8	49.4	50.3	57.9	58.3	67.2	66.9	77.1
	>=100	20.5	22.8	23.0	25.6	28.4	31.5	34.3	38.2	40.9	45.4	48.0	53.3	55.6	61.8	63.8	71.0

- The values shown are based upon the ASCE 7-05 Analytical Procedure, Components & Cladding, Method 2. The corner end zone width of a wall is the smaller of 0.1 x wall length or 0.4 x wall height, but not less than 0.04 x wall length or 3'-0".
- For a mean roof height of 30 feet or less, the stated psf loads in the table above may be reduced 2.5 percent to reflect the values shown in the IRC code.

**ASCE 7:** A design standard published by the American Society of Civil Engineers (ASCE) that is referenced by the International Building Code (IBC). ASCE 7 – Minimum Design Loads for Buildings and Other Structures establishes the live, snow, seismic and wind loads for the building code.

**Components and Cladding (CC):** Structural components that do not qualify on their own as a MWFRS (see below). An individual wall stud is an example of a CC element.

**Effective Wind Area:** A factor used to calculate the wind load on a stud or column. The effective wind area is the greater value of the following two equations:

1. the square of the stud height divided by 3 or  $L^2/3$  (see adjacent value table) or
2. the stud height multiplied by the tributary width (or o.c. spacing for studs).

Effective Wind Area	
Wall Height [ft]	Stud/Column Effective Wind Area [ft <sup>2</sup> ]
>= 18	100
16	85
14	65
12	48
10	33
8	21

**Exposure Category:** A factor used to calculate the design wind load (pressure) that accounts for the type of terrain surrounding the structure in question. The wind pressure will be less within a housing development versus a structure near a body of water. The following is summary of the exposure categories:

- B = Urban and suburban (subdivision) areas, forest land
- C = Open land with scattered obstructions of heights less than 30 feet
- D = Flat unobstructed areas and water surfaces

**In-Plane Loading:** Lateral loads applied along the length of the wall are referred to as in-plane loading (see detail below). Wind loading applied parallel to the wall length must be determined by the design professional of record. Bracing, braced wall panels and tie-down anchors at corners shall be determined by design professional of record and be in accordance with applicable building code

**Main Wind Force-Resisting System (MWFRS):** A classification of structural components. MWFRS generally refers to a system of elements that receives wind loading from more than one surface of the structure. An example of a MWFRS is an exterior wood shear wall. The shear wall receives seismic and wind load along its length (in-plane loading) and wind load perpendicular to its surface (out-of-plane loading).

**Out-of-Plane Loading:** Wind loading perpendicular to the wall length (see detail below). Tables shown in this guide are based on out-of-plane loading only.

**Wind Speed:** The value established by the building code or local building department which is then used, along with other factors, to determine the wind load. Wind Speed in ASCE 7 is now based upon a 3 second gust, determined by meteorological data and statistical analysis. Wind speed is provided in units of miles per hour (mph).

**Wind Load:** The design load used to size a stud or column. The wind load is determined by taking the wind speed and applying all the necessary factors per ASCE 7, including the geometry of the structure, exposure, etc. In some areas, the design wind load is provided for residential construction by the building code jurisdiction. Wind load is in units of pounds per square foot (psf).

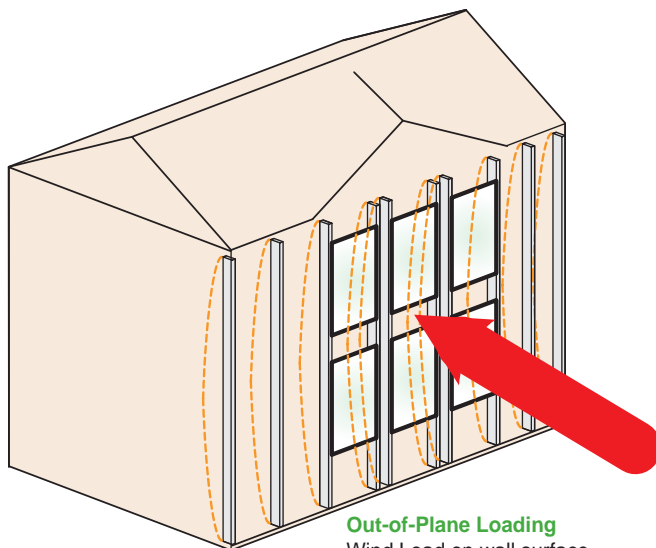

**Out-of-Plane Loading**  
Wind Load on wall surface  
Stress and deflection of studs caused by perpendicular loading

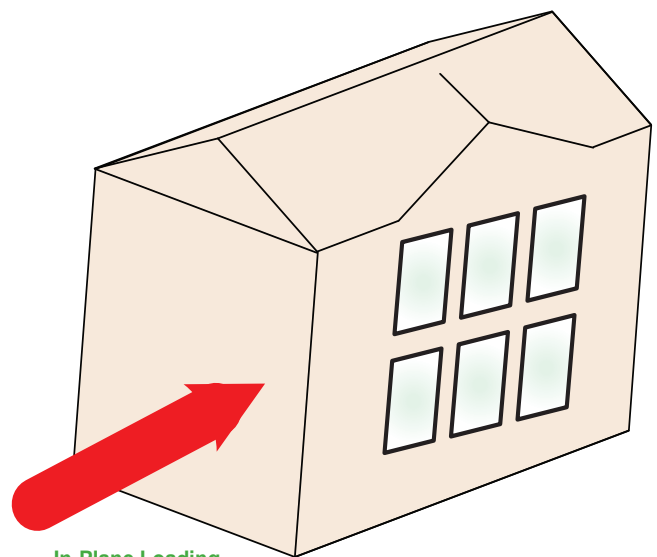

**In-Plane Loading**  
Racking of wall caused by wind and/or seismic loading on opposite wall, applying parallel force on window wall

## VERSA-STUD® Design

**Given: Wall as shown**

**Wall Height:** 16'-0"

**Preliminary Stud Spacing:** 16" o.c.

**Roof Load:** 40 psf snow load, 15 psf dead load. BCI® rafter framing with an 18'-0" horizontal span and 2'-0" overhang

**Wind Load:** 20 psf load per local building department  
(see *wind load section for more information on determining wind loading*)

**Deflection Limit:** Possible brittle finish = L/240  
(IRC Table R301.7)

### Solution:

#### Stud Design

Determine Vertical Load

$$\text{Roof Tributary Width} = [18'-0" / 2] + 2'-0" = 11'-0"$$

$$\text{Snow Load [plf]} = 40 \text{ lb/ft}^2 \times 11 \text{ ft} = 440 \text{ lb/ft}$$

$$\text{Snow Load [lb]} = 440 \text{ lb/ft} \times [16 \text{ in} / 12] = 587 \text{ lb}$$

$$\text{Dead Load [plf]} = 15 \text{ lb/ft}^2 \times 11 \text{ ft} = 165 \text{ lb/ft}$$

$$\text{Wall Weight [lb]} = 10 \text{ lb/ft}^2 \times 16 \text{ ft} \times [16 \text{ in} / 12] = 213 \text{ lb}$$

(assume wall self-weight of 10 psf)

$$\text{Dead Load [lb]} = 165 \text{ lb/ft} \times [16 \text{ in} / 12] = 220 \text{ lb}$$

$$\text{Total Load [lb]} = 587 \text{ lb} + 220 \text{ lb} + 213 \text{ lb} = 1020 \text{ lb}$$

Go to **VERSA-STUD® 1.7 2650 1½" x 5½" load charts, page 10**

L/240, 16 ft wall height

Max. Loading, Single Stud,  
Vertical Load = 3609 lb > 1020 lb **OK!**

20 PSF Wind Load, Max. Stud Spacing = 16" **OK!**

**VERSA-STUD® 1.7 2650 1½" x 5½" @ 16" o.c. OK!**

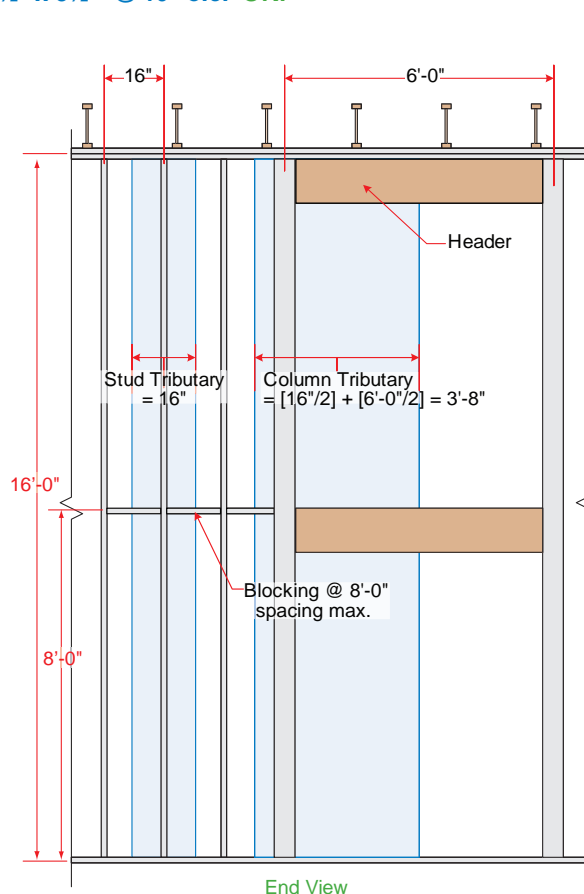

## VERSA-LAM® Column Design

**Determine Vertical Load**

$$\text{Column Tributary Width} = [6'-0" / 2] + [16 \text{ in} / 2] = 3'-8"$$

$$\text{Snow Load [lb]} = 440 \text{ lb/ft} \times 3'-8" = 1615 \text{ lb}$$

$$\text{Dead Load [lb]} = 165 \text{ lb/ft} \times 3'-8" = 606 \text{ lb}$$

$$\text{Total Load [lb]} = 1615 \text{ lb} + 606 \text{ lb} = 2221 \text{ lb}$$

$$\text{Wind Load [plf]} = 20 \text{ lb/ft}^2 \times 3'-8" = 73.4 \text{ lb/ft}$$

Go to **VERSA-LAM® 1.7 2650 Exterior Wall Column Table, page 13**

L/240, 16 ft wall height

#### 3½" x 5¼" Column

$$\text{Vertical Load} = 7358 \text{ lb} > 2221 \text{ lb} \text{ OK!}$$

$$\text{Wind Load} = 55.6 \text{ lb/ft} < 73.4 \text{ lb/ft} \text{ NOT OK}$$

#### 5¼" x 5¼" Column

$$\text{Vertical Load} = 10680 \text{ lb} > 2221 \text{ lb} \text{ OK!}$$

$$\text{Wind Load} = 83.4 \text{ lb/ft} > 73.4 \text{ lb/ft} \text{ OK!}$$

**VERSA-LAM® 1.7 2650 Column 5¼" x 5¼" OK!**

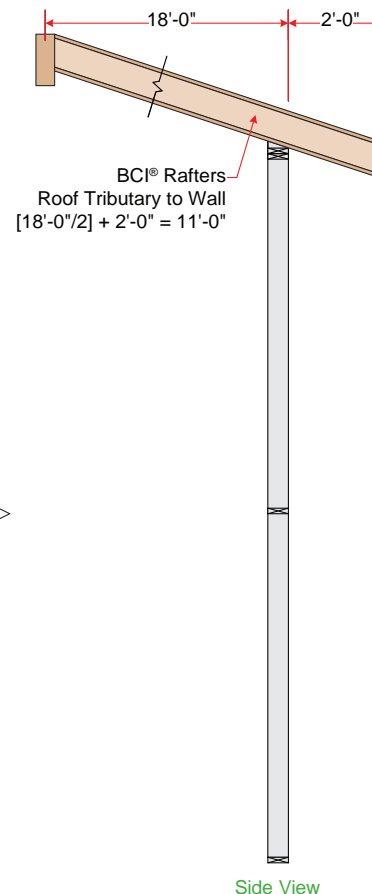



# Stud Load Tables

## VERSA-STUD® 1.7 2650 1½" x 3½"

Deflection Limit	Wall Height [ft]	MAXIMUM LOADING				10 PSF WIND LOAD SPACING & TRIBUTARY			15 PSF WIND LOAD SPACING & TRIBUTARY			20 PSF WIND LOAD SPACING & TRIBUTARY		
		Single Stud		Double Stud		Single Stud		Double Stud	Single Stud		Double Stud	Single Stud		Double Stud
		Vertical Load [lb]	Wind Load [lb/ft]	Vertical Load [lb]	Wind Load [lb/ft]	Max Stud Spacing [in]	Max Tributary Width [in]	Max Tributary Width [in]	Max Stud Spacing [in]	Max Tributary Width [in]	Max Tributary Width [in]	Max Stud Spacing [in]	Max Tributary Width [in]	Max Tributary Width [in]
L/360	8	2953	37.7	4297	75.3	24	45.2	90.4	24	30.1	60.3	19.2	22.6	45.2
	9	2953	26.5	4262	52.9	24	31.7	63.5	19.2	21.2	42.3	12	15.9	31.7
	10	2672	19.3	4172	38.6	19.2	23.1	46.3	12	15.4	30.9	8	11.6	23.1
	11	2257	14.5	4022	29.0	16	17.4	34.8	8	11.6	23.2	8	8.7	17.4
	12	1931	11.2	3794	22.3	12	13.4	26.8	8	8.9	17.9	6	6.7	13.4
	13	1671	8.8	3309	17.6	8	10.5	21.1	6	7.0	14.0	4	5.3	10.5
L/240	8	2953	37.7	4297	75.3	24	45.2	90.4	24	30.1	60.3	19.2	22.6	45.2
	9	2863	26.5	4262	52.9	24	31.7	63.5	19.2	21.2	42.3	12	15.9	31.7
	10	2405	19.3	3796	38.6	24	34.7	69.4	19.2	23.1	46.3	16	17.4	34.7
	11	2047	14.5	3654	29.0	24	26.1	52.2	16	17.4	34.8	12	13.0	26.1
	12	1764	11.2	3453	22.3	19.2	20.1	40.2	12	13.4	26.8	8	10.0	20.1
	13	1535	8.8	3029	17.6	12	15.8	31.6	8	10.5	21.1	6	7.9	15.8
L/180	8	2953	37.7	4297	75.3	24	45.2	90.4	24	30.1	60.3	19.2	22.6	45.2
	9	2549	26.5	3509	52.9	24	31.7	63.5	24	42.3	84.6	24	31.7	63.5
	10	2168	19.3	3446	38.6	24	46.3	92.6	24	30.9	61.7	19.2	23.1	46.3
	11	1863	14.5	3324	29.0	24	34.8	69.5	19.2	23.2	46.4	16	17.4	34.8
	12	1617	11.2	3151	22.3	24	26.8	53.6	16	17.9	35.7	12	13.4	26.8
	13	1416	8.8	2781	17.6	19.2	21.1	42.1	12	14.0	28.1	8	10.5	21.1
L/120	8	2241	113.0	2705	226.0	24	135.6	271.2	24	90.4	180.8	24	67.8	135.6
	9	1979	79.4	2783	158.7	24	95.2	190.4	24	63.5	127.0	24	47.6	95.2
	10	1740	57.8	2782	115.7	24	69.4	138.8	24	46.3	92.6	24	34.7	69.4
	11	1533	43.5	2722	86.9	24	52.2	104.3	24	34.8	69.5	24	26.1	52.2
	12	1356	33.5	2612	67.0	24	40.2	80.3	24	26.8	53.6	19.2	20.1	40.2
	13	1205	26.3	2345	52.7	24	31.6	63.2	19.2	21.1	42.1	12	15.8	31.6
14	1077	21.1	2100	42.2	24	25.3	50.6	16	16.9	33.7	12	12.6	25.3	

Deflection Limit	Wall Height [ft]	MAXIMUM LOADING				25 PSF WIND LOAD SPACING & TRIBUTARY			30 PSF WIND LOAD SPACING & TRIBUTARY			40 PSF WIND LOAD SPACING & TRIBUTARY		
		Single Stud		Double Stud		Single Stud		Double Stud	Single Stud		Double Stud	Single Stud		Double Stud
		Vertical Load [lb]	Wind Load [lb/ft]	Vertical Load [lb]	Wind Load [lb/ft]	Max Stud Spacing [in]	Max Tributary Width [in]	Max Tributary Width [in]	Max Stud Spacing [in]	Max Tributary Width [in]	Max Tributary Width [in]	Max Stud Spacing [in]	Max Tributary Width [in]	Max Tributary Width [in]
L/360	8	2953	37.7	4297	75.3	16	18.1	36.2	12	15.1	30.1	8	11.3	22.6
	9	2953	26.5	4262	52.9	12	12.7	25.4	8	10.6	21.2	6	7.9	15.9
	10	2672	19.3	4172	38.6	8	9.3	18.5	6	7.7	15.4	4	5.8	11.6
	11	2257	14.5	4022	29.0	6	7.0	13.9	4	5.8	11.6	4	4.3	8.7
	12	1931	11.2	3794	22.3	4	5.4	10.7	4	4.5	8.9	--	3.3	6.7
	13	1671	8.8	3309	17.6	4	4.2	8.4	--	3.5	7.0	--	2.6	5.3
L/240	8	2953	37.7	4297	75.3	24	45.2	90.4	24	30.1	60.3	19.2	22.6	45.2
	9	2863	26.5	4262	52.9	24	31.7	63.5	19.2	21.2	42.3	12	15.9	31.7
	10	2405	19.3	3796	38.6	12	13.9	27.8	8	11.6	23.1	8	8.7	17.4
	11	2047	14.5	3654	29.0	8	10.4	20.9	8	8.7	17.4	6	6.5	13.0
	12	1764	11.2	3453	22.3	8	8.0	16.1	6	6.7	13.4	4	5.0	10.0
	13	1535	8.8	3029	17.6	6	6.3	12.6	4	5.3	10.5	--	3.9	7.9
L/180	8	2953	37.7	4297	75.3	24	45.2	90.4	24	30.1	60.3	19.2	22.6	45.2
	9	2549	26.5	3509	52.9	24	31.7	63.5	19.2	21.2	42.3	12	15.9	31.7
	10	2168	19.3	3446	38.6	16	18.5	37.0	12	15.4	30.9	8	11.6	23.1
	11	1863	14.5	3324	29.0	12	13.9	27.8	8	11.6	23.2	8	8.7	17.4
	12	1617	11.2	3151	22.3	8	10.7	21.4	8	8.9	17.9	6	6.7	13.4
	13	1416	8.8	2781	17.6	8	8.4	16.9	6	7.0	14.0	4	5.3	10.5
L/120	8	2241	113.0	2705	226.0	24	54.2	108.5	24	45.2	90.4	24	33.9	67.8
	9	1979	79.4	2783	158.7	24	38.1	76.2	24	31.7	63.5	19.2	23.8	47.6
	10	1740	57.8	2782	115.7	24	27.8	55.5	19.2	23.1	46.3	16	17.4	34.7
	11	1533	43.5	2722	86.9	19.2	20.9	41.7	16	17.4	34.8	12	13.0	26.1
	12	1356	33.5	2612	67.0	16	16.1	32.1	12	13.4	26.8	8	10.0	20.1
	13	1205	26.3	2345	52.7	12	12.6	25.3	8	10.5	21.1	6	7.9	15.8
14	1077	21.1	2100	42.2	8	10.1	20.2	8	8.4	16.9	6	6.3	12.6	

**Notes**

- Wall stud analysis per 2005 National Design Specification (NDS) for Wood Construction.
- For 3-ply and 4-ply built up columns, multiply double stud table values by 1.5 and 2.0.
- Full depth blocking required at a maximum spacing of 8'-0" for single studs.
- Structural sheathing or structural siding installed on one side of wall.

- Double stud values assume unsupported lateral length of 7'-0".
- Table assumes wind load duration factor of 1.6 and vertical load duration factor of 1.0.
- Table assumes compression perpendicular to grain for plate of 450 psi.
- Vertical dead load may not exceed 50% of the total vertical load.
- Repetitive member increase for bending (1.04) applied to single studs only.
- Compression perpendicular to grain stress adjusted per NDS 3.10.4 for single studs only.

## VERSA-STUD® 1.7 2650 1½" x 5½"

Deflection Limit	Wall Height [ft]	MAXIMUM LOADING				10 PSF WIND LOAD SPACING & TRIBUTARY			15 PSF WIND LOAD SPACING & TRIBUTARY			20 PSF WIND LOAD SPACING & TRIBUTARY		
		Single Stud		Double Stud		Single Stud		Double Stud	Single Stud		Double Stud	Single Stud		Double Stud
		Vertical Load [lb]	Wind Load [lb/ft]	Vertical Load [lb]	Wind Load [lb/ft]	Max Stud Spacing [in]	Max Tributary Width [in]	Max Tributary Width [in]	Max Stud Spacing [in]	Max Tributary Width [in]	Max Tributary Width [in]	Max Stud Spacing [in]	Max Tributary Width [in]	Max Tributary Width [in]
L/360	10	4641	74.8	6615	149.6	24	89.8	179.6	24	59.9	119.7	24	44.9	89.8
	12	4641	43.3	6676	86.6	24	52.0	103.9	24	34.6	69.3	24	26.0	52.0
	14	4641	27.3	6624	54.5	24	32.7	65.4	19.2	21.8	43.6	16	16.4	32.7
	16	4025	18.3	6442	36.5	19.2	21.9	43.8	12	14.6	29.2	8	11.0	21.9
	17	3615	15.2	6291	30.5	16	18.3	36.6	12	12.2	24.4	8	9.1	18.3
	18	3266	12.8	6093	25.7	12	15.4	30.8	8	10.3	20.5	6	7.7	15.4
	19	2965	10.9	5850	21.8	12	13.1	26.2	8	8.7	17.5	6	6.5	13.1
20	2704	9.4	5337	18.7	8	11.2	22.4	6	7.5	15.0	4	5.6	11.2	
L/240	10	4641	112.2	5870	224.5	24	134.7	269.4	24	89.8	179.6	24	67.3	134.7
	12	4641	65.0	6006	129.9	24	77.9	155.9	24	52.0	103.9	24	39.0	77.9
	14	4493	40.9	5987	81.8	24	49.1	98.2	24	32.7	65.4	24	24.5	49.1
	16	3609	27.4	5822	54.8	24	32.9	65.8	19.2	21.9	43.8	16	16.4	32.9
	17	3261	22.8	5682	45.7	24	27.4	54.8	16	18.3	36.6	12	13.7	27.4
	18	2960	19.2	5507	38.5	19.2	23.1	46.2	12	15.4	30.8	8	11.5	23.1
	19	2699	16.4	5296	32.7	19.2	19.6	39.3	12	13.1	26.2	8	9.8	19.6
20	2471	14.0	4854	28.1	16	16.8	33.7	8	11.2	22.4	8	8.4	16.8	
L/180	10	4641	149.6	5077	299.3	24	179.6	359.2	24	119.7	239.4	24	89.8	179.6
	12	4641	86.6	5326	173.2	24	103.9	207.8	24	69.3	138.6	24	52.0	103.9
	14	3968	54.5	5368	109.1	24	65.4	130.9	24	43.6	87.3	24	32.7	65.4
	16	3242	36.5	5247	73.1	24	43.8	87.7	24	29.2	58.5	19.2	21.9	43.8
	17	2948	30.5	5131	60.9	24	36.6	73.1	24	24.4	48.7	16	18.3	36.6
	18	2691	25.7	4982	51.3	24	30.8	61.6	19.2	20.5	41.1	12	15.4	30.8
	19	2465	21.8	4807	43.6	24	26.2	52.4	16	17.5	34.9	12	13.1	26.2
20	2267	18.7	4427	37.4	19.2	22.4	44.9	12	15.0	29.9	8	11.2	22.4	
L/120	10	3704	224.5	3254	448.9	24	269.4	538.7	24	179.6	359.2	24	134.7	269.4
	12	3459	129.9	3887	259.8	24	155.9	311.8	24	103.9	207.8	24	77.9	155.9
	14	3009	81.8	4135	163.6	24	98.2	196.3	24	65.4	130.9	24	49.1	98.2
	16	2577	54.8	4166	109.6	24	65.8	131.5	24	43.8	87.7	24	32.9	65.8
	17	2385	45.7	4119	91.4	24	54.8	109.7	24	36.6	73.1	24	27.4	54.8
	18	2207	38.5	4040	77.0	24	46.2	92.4	24	30.8	61.6	19.2	23.1	46.2
	19	2049	32.7	3934	65.5	24	39.3	78.5	24	26.2	52.4	19.2	19.6	39.3
20	1903	28.1	3666	56.1	24	33.7	67.3	19.2	22.4	44.9	16	16.8	33.7	

Deflection Limit	Wall Height [ft]	MAXIMUM LOADING				25 PSF WIND LOAD SPACING & TRIBUTARY			30 PSF WIND LOAD SPACING & TRIBUTARY			40 PSF WIND LOAD SPACING & TRIBUTARY		
		Single Stud		Double Stud		Single Stud		Double Stud	Single Stud		Double Stud	Single Stud		Double Stud
		Vertical Load [lb]	Wind Load [lb/ft]	Vertical Load [lb]	Wind Load [lb/ft]	Max Stud Spacing [in]	Max Tributary Width [in]	Max Tributary Width [in]	Max Stud Spacing [in]	Max Tributary Width [in]	Max Tributary Width [in]	Max Stud Spacing [in]	Max Tributary Width [in]	Max Tributary Width [in]
L/360	10	4641	74.8	6615	149.6	24	35.9	71.8	24	29.9	59.9	19.2	22.4	44.9
	12	4641	43.3	6676	86.6	19.2	20.8	41.6	16	17.3	34.6	12	13.0	26.0
	14	4641	27.3	6624	54.5	12	13.1	26.2	8	10.9	21.8	8	8.2	16.4
	16	4027	18.3	6442	36.5	8	8.8	17.5	6	7.3	14.6	4	5.5	11.0
	17	3617	15.2	6291	30.5	6	7.3	14.6	6	6.1	12.2	4	4.6	9.1
	18	3267	12.8	6093	25.7	6	6.2	12.3	4	5.1	10.3	--	3.8	7.7
	19	2966	10.9	5850	21.8	4	5.2	10.5	4	4.4	8.7	--	3.3	6.5
20	2704	9.4	5337	18.7	4	4.5	9.0	--	3.7	7.5	--	2.8	5.6	
L/240	10	4641	112.2	5870	224.5	24	53.9	107.7	24	44.9	89.8	24	33.7	67.3
	12	4641	65.0	6006	129.9	24	31.2	62.4	24	26.0	52.0	19.2	19.5	39.0
	14	4493	40.9	5987	81.8	19.2	19.6	39.3	16	16.4	32.7	12	12.3	24.5
	16	3610	27.4	5822	54.8	12	13.2	26.3	8	11.0	21.9	8	8.2	16.4
	17	3261	22.8	5682	45.7	8	11.0	21.9	8	9.1	18.3	6	6.9	13.7
	18	2961	19.2	5507	38.5	8	9.2	18.5	6	7.7	15.4	4	5.8	11.5
	19	2699	16.4	5296	32.7	6	7.9	15.7	6	6.5	13.1	4	4.9	9.8
20	2471	14.0	4854	28.1	6	6.7	13.5	4	5.6	11.2	4	4.2	8.4	
L/180	10	4641	149.6	5077	299.3	24	71.8	143.7	24	59.9	119.7	24	44.9	89.8
	12	4641	86.6	5326	173.2	24	41.6	83.1	24	34.6	69.3	24	26.0	52.0
	14	3968	54.5	5368	109.1	24	26.2	52.4	19.2	21.8	43.6	16	16.4	32.7
	16	3242	36.5	5247	73.1	16	17.5	35.1	12	14.6	29.2	8	11.0	21.9
	17	2948	30.5	5131	60.9	12	14.6	29.2	12	12.2	24.4	8	9.1	18.3
	18	2691	25.7	4982	51.3	12	12.3	24.6	8	10.3	20.5	6	7.7	15.4
	19	2466	21.8	4807	43.6	8	10.5	20.9	8	8.7	17.5	6	6.5	13.1
20	2267	18.7	4427	37.4	8	9.0	18.0	6	7.5	15.0	4	5.6	11.2	
L/120	10	3705	224.5	3254	448.9	24	107.7	215.5	24	89.8	179.6	24	67.3	134.7
	12	3459	129.9	3887	259.8	24	62.4	124.7	24	52.0	103.9	24	39.0	77.9
	14	3008	81.8	4135	163.6	24	39.3	78.5	24	32.7	65.4	24	24.5	49.1
	16	2577	54.8	4166	109.6	24	26.3	52.6	19.2	21.9	43.8	16	16.4	32.9
	17	2384	45.7	4119	91.4	19.2	21.9	43.9	16	18.3	36.6	12	13.7	27.4
	18	2209	38.5	4040	77.0	16	18.5	37.0	12	15.4	30.8	8	11.5	23.1
	19	2049	32.7	3934	65.5	12	15.7	31.4	12	13.1	26.2	8	9.8	19.6
20	1904	28.1	3666	56.1	12	13.5	26.9	8	11.2	22.4	8	8.4	16.8	

**Notes**

- Wall stud analysis per 2005 National Design Specification (NDS) for Wood Construction.
- For 3-ply and 4-ply built up columns, multiply double stud table values by 1.5 and 2.0.
- Full depth blocking required at a maximum spacing of 8'-0" for single studs.
- Structural sheathing or structural siding installed on one side of wall.

- Double stud values assume unsupported lateral length of 7'-0".
- Table assumes wind load duration factor of 1.6 and vertical load duration factor of 1.0.
- Table assumes compression perpendicular to grain for plate of 450 psi.
- Vertical dead load may not exceed 50% of the total vertical load.
- Repetitive member increase for bending (1.04) applied to single studs only.
- Compression perpendicular to grain stress adjusted per NDS 3.10.4 for single studs only.

## VERSA-STUD® 1.7 2650 1½" x 7¼"

Deflection Limit	Wall Height [ft]	MAXIMUM LOADING				10 PSF WIND LOAD SPACING & TRIBUTARY			15 PSF WIND LOAD SPACING & TRIBUTARY			20 PSF WIND LOAD SPACING & TRIBUTARY		
		Single Stud		Double Stud		Single Stud		Double Stud	Single Stud		Double Stud	Single Stud		Double Stud
		Vertical Load [lb]	Wind Load [lb/ft]	Vertical Load [lb]	Wind Load [lb/ft]	Max Stud Spacing [in]	Max Tributary Width [in]	Max Tributary Width [in]	Max Stud Spacing [in]	Max Tributary Width [in]	Max Tributary Width [in]	Max Stud Spacing [in]	Max Tributary Width [in]	Max Tributary Width [in]
L/360	10	6117	171.4	8249	342.8	24	205.7	411.3	24	137.1	274.2	24	102.8	205.7
	12	6117	99.2	8529	198.4	24	119.0	238.0	24	79.3	158.7	24	59.5	119.0
	14	6117	62.5	8669	124.9	24	74.9	149.9	24	50.0	99.9	24	37.5	74.9
	16	6117	41.8	8713	83.7	24	50.2	100.4	24	33.5	66.9	24	25.1	50.2
	18	6117	29.4	8669	58.8	24	35.3	70.5	19.2	23.5	47.0	16	17.6	35.3
	20	5782	21.4	8529	42.8	24	25.7	51.4	16	17.1	34.3	12	12.9	25.7
	22	4892	16.1	8278	32.2	19.2	19.3	38.6	12	12.9	25.8	8	9.7	19.3
24	4192	12.4	7888	24.8	12	14.9	29.8	8	9.9	19.8	6	7.4	14.9	
L/240	10	6117	257.1	6911	514.2	24	308.5	617.0	24	205.7	411.3	24	154.2	308.5
	12	6117	148.8	7405	297.5	24	178.5	357.1	24	119.0	238.0	24	89.3	178.5
	14	6117	93.7	7675	187.4	24	112.4	224.8	24	74.9	149.9	24	56.2	112.4
	16	6117	62.8	7791	125.5	24	75.3	150.6	24	50.2	100.4	24	37.7	75.3
	18	6093	44.1	7786	88.2	24	52.9	105.8	24	35.3	70.5	24	26.4	52.9
	20	5141	32.1	7668	64.3	24	38.6	77.1	24	25.7	51.4	19.2	19.3	38.6
	22	4392	24.1	7437	48.3	24	29.0	57.9	19.2	19.3	38.6	12	14.5	29.0
24	3794	18.6	7099	37.2	19.2	22.3	44.6	12	14.9	29.8	8	11.2	22.3	
L/180	10	6117	342.8	5354	685.5	24	411.3	822.6	24	274.2	548.4	24	205.7	411.3
	12	6117	198.4	6183	396.7	24	238.0	476.1	24	158.7	317.4	24	119.0	238.0
	14	6117	124.9	6627	249.8	24	149.9	299.8	24	99.9	199.9	24	74.9	149.9
	16	6117	83.7	6853	167.4	24	100.4	200.8	24	66.9	133.9	24	50.2	100.4
	18	5334	58.8	6919	117.5	24	70.5	141.1	24	47.0	94.0	24	35.3	70.5
	20	4571	42.8	6855	85.7	24	51.4	102.8	24	34.3	68.6	24	25.7	51.4
	22	3947	32.2	6675	64.4	24	38.6	77.3	24	25.8	51.5	19.2	19.3	38.6
24	3441	24.8	6397	49.6	24	29.8	59.5	19.2	19.8	39.7	12	14.9	29.8	
L/120	10	6117	408.5	3869	785.7	24	490.3	942.8	24	326.8	628.5	24	245.1	471.4
	12	4901	283.7	3603	545.6	24	340.5	654.7	24	227.0	436.5	24	170.2	327.4
	14	4589	187.4	4258	374.7	24	224.8	449.7	24	149.9	299.8	24	112.4	224.8
	16	4349	125.5	4863	251.1	24	150.6	301.3	24	100.4	200.8	24	75.3	150.6
	18	3948	88.2	5168	176.3	24	105.8	211.6	24	70.5	141.1	24	52.9	105.8
	20	3533	64.3	5284	128.5	24	77.1	154.2	24	51.4	102.8	24	38.6	77.1
	22	3150	48.3	5258	96.6	24	57.9	115.9	24	38.6	77.3	24	29.0	57.9
24	2812	37.2	5124	74.4	24	44.6	89.3	24	29.8	59.5	19.2	22.3	44.6	

Deflection Limit	Wall Height [ft]	MAXIMUM LOADING				25 PSF WIND LOAD SPACING & TRIBUTARY			30 PSF WIND LOAD SPACING & TRIBUTARY			40 PSF WIND LOAD SPACING & TRIBUTARY		
		Single Stud		Double Stud		Single Stud		Double Stud	Single Stud		Double Stud	Single Stud		Double Stud
		Vertical Load [lb]	Wind Load [lb/ft]	Vertical Load [lb]	Wind Load [lb/ft]	Max Stud Spacing [in]	Max Tributary Width [in]	Max Tributary Width [in]	Max Stud Spacing [in]	Max Tributary Width [in]	Max Tributary Width [in]	Max Stud Spacing [in]	Max Tributary Width [in]	Max Tributary Width [in]
L/360	10	6117	171.4	8249	342.8	24	82.3	164.5	24	68.6	137.1	24	51.4	102.8
	12	6117	99.2	8529	198.4	24	47.6	95.2	24	39.7	79.3	24	29.8	59.5
	14	6117	62.5	8669	124.9	24	30.0	60.0	24	25.0	50.0	16	18.7	37.5
	16	6117	41.8	8713	83.7	19.2	20.1	40.2	16	16.7	33.5	12	12.6	25.1
	18	6117	29.4	8669	58.8	12	14.1	28.2	8	11.8	23.5	8	8.8	17.6
	20	5782	21.4	8529	42.8	8	10.3	20.6	8	8.6	17.1	6	6.4	12.9
	22	4892	16.1	8278	32.2	6	7.7	15.5	6	6.4	12.9	4	4.8	9.7
24	4192	12.4	7888	24.8	4	6.0	11.9	4	5.0	9.9	--	3.7	7.4	
L/240	10	6117	257.1	6911	514.2	24	123.4	246.8	24	102.8	205.7	24	77.1	154.2
	12	6117	148.8	7405	297.5	24	71.4	142.8	24	59.5	119.0	24	44.6	89.3
	14	6117	93.7	7675	187.4	24	45.0	89.9	24	37.5	74.9	24	28.1	56.2
	16	6117	62.8	7791	125.5	24	30.1	60.3	24	25.1	50.2	16	18.8	37.7
	18	6093	44.1	7786	88.2	19.2	21.2	42.3	16	17.6	35.3	12	13.2	26.4
	20	5141	32.1	7668	64.3	12	15.4	30.8	12	12.9	25.7	8	9.6	19.3
	22	4392	24.1	7437	48.3	8	11.6	23.2	8	9.7	19.3	6	7.2	14.5
24	3794	18.6	7099	37.2	8	8.9	17.9	6	7.4	14.9	4	5.6	11.2	
L/180	10	6117	342.8	5354	685.5	24	164.5	329.1	24	137.1	274.2	24	102.8	205.7
	12	6117	198.4	6183	396.7	24	95.2	190.4	24	79.3	158.7	24	59.5	119.0
	14	6117	124.9	6627	249.8	24	60.0	119.9	24	50.0	99.9	24	37.5	74.9
	16	6117	83.7	6853	167.4	24	40.2	80.3	24	33.5	66.9	24	25.1	50.2
	18	5334	58.8	6919	117.5	24	28.2	56.4	19.2	23.5	47.0	16	17.6	35.3
	20	4571	42.8	6855	85.7	19.2	20.6	41.1	16	17.1	34.3	12	12.9	25.7
	22	3947	32.2	6675	64.4	12	15.5	30.9	12	12.9	25.8	8	9.7	19.3
24	3441	24.8	6397	49.6	8	11.9	23.8	8	9.9	19.8	6	7.4	14.9	
L/120	10	6117	408.5	3869	785.7	24	196.1	377.1	24	163.4	314.3	24	122.6	235.7
	12	4901	283.7	3603	545.6	24	136.2	261.9	24	113.5	218.2	24	85.1	163.7
	14	4589	187.4	4258	374.7	24	89.9	179.9	24	74.9	149.9	24	56.2	112.4
	16	4349	125.5	4863	251.1	24	60.3	120.5	24	50.2	100.4	24	37.7	75.3
	18	3948	88.2	5168	176.3	24	42.3	84.6	24	35.3	70.5	24	26.4	52.9
	20	3533	64.3	5284	128.5	24	30.8	61.7	24	25.7	51.4	19.2	19.3	38.6
	22	3150	48.3	5258	96.6	19.2	23.2	46.4	19.2	19.3	38.6	12	14.5	29.0
24	2812	37.2	5124	74.4	16	17.9	35.7	12	14.9	29.8	8	11.2	22.3	

**Notes**

- Wall stud analysis per 2005 National Design Specification (NDS) for Wood Construction.
- For 3-ply and 4-ply built up columns, multiply double stud table values by 1.5 and 2.0.
- Full depth blocking required at a maximum spacing of 8'-0" for single studs.
- Structural sheathing or structural siding installed on one side of wall.

- Double stud values assume unsupported lateral length of 7'-0".
- Table assumes wind load duration factor of 1.6 and vertical load duration factor of 1.0.
- Table assumes compression perpendicular to grain for plate of 450 psi.
- Vertical dead load may not exceed 50% of the total vertical load.
- Repetitive member increase for bending (1.04) applied to single studs only.
- Compression perpendicular to grain stress adjusted per NDS 3.10.4 for single studs only.

### Multiple-Ply Stud Connections

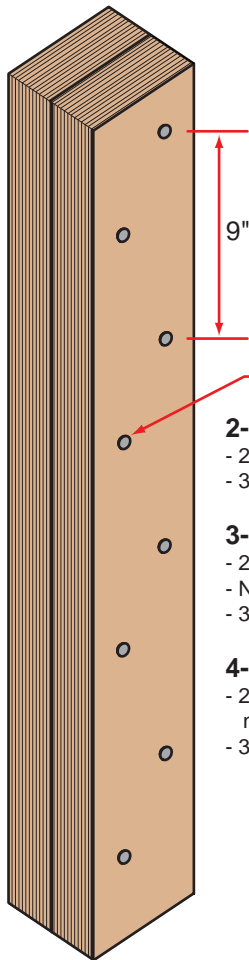

- Stagger rows
- 2-Ply 1½" Connection**  
 - 2 rows 10d (min) nails @ 9" o.c.  
 - 3 rows for 9¼" and greater studs
- 3-Ply 1½" Connection**  
 - 2 rows 10d (min) nails @ 9" o.c.  
 - Nail from each side  
 - 3 rows for 9¼" and greater studs
- 4-Ply 1½" Connection**  
 - 2 rows 10d (min) nails @ 9" o.c.,  
 nailed from each ply to each ply  
 - 3 rows for 9¼" and greater studs

### Header to Column

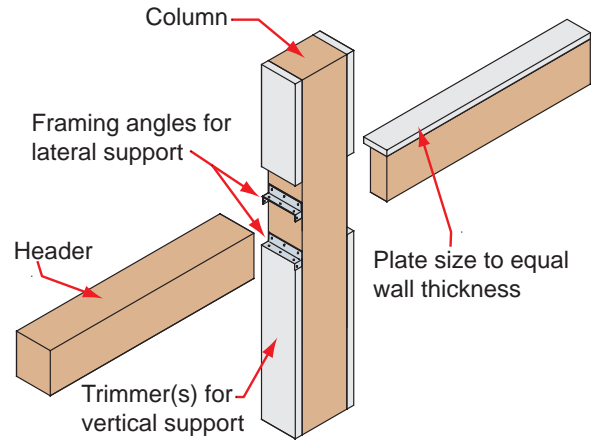

### Column to Bottom Plate

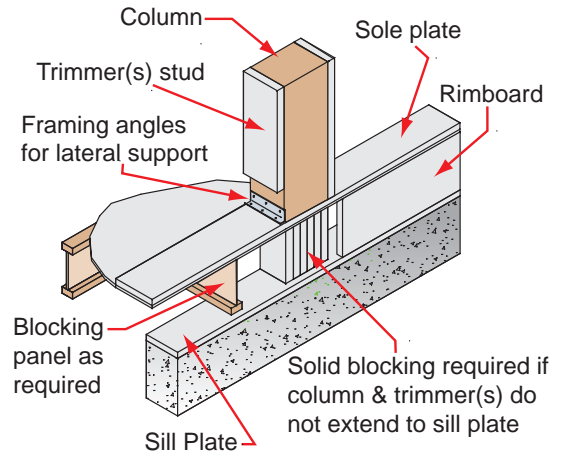

### 3½" Studs - 24" o.c.

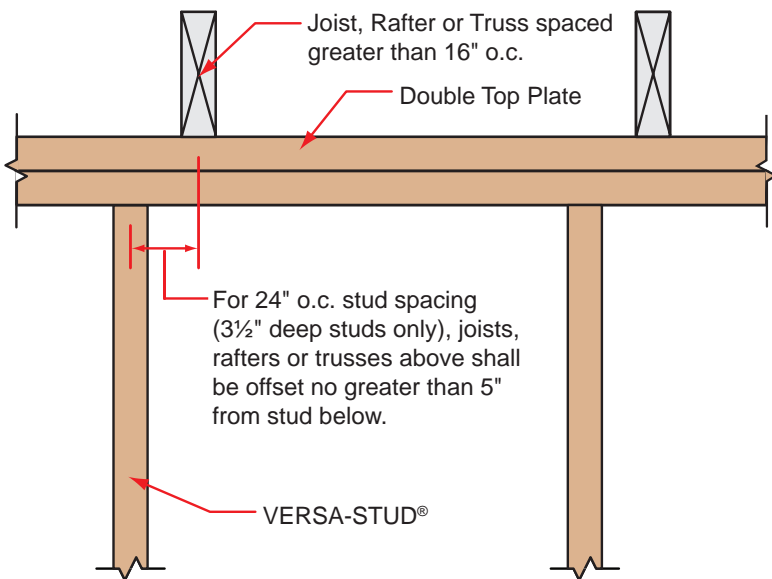

### Column to Top Plate

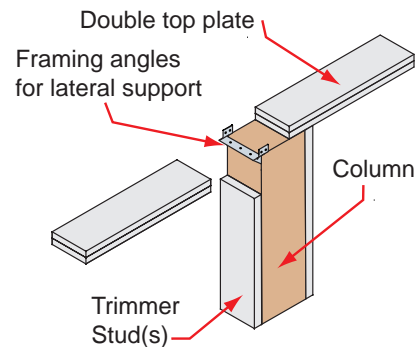

Deflection Limit	Column Height [ft]	3½" Thick Wall						5½" Thick Wall						7¼" Thick Wall						
		3½" x 3½"		5¼" x 3½"		7" x 3½"		3½" x 5¼"		5¼" x 5¼"		7" x 5¼"		3½" x 7"		5¼" x 7"		7" x 7"		
		Vertical Load [lb]	Wind Load [lb/ft]	Vertical Load [lb]	Wind Load [lb/ft]	Vertical Load [lb]	Wind Load [lb/ft]	Vertical Load [lb]	Wind Load [lb/ft]	Vertical Load [lb]	Wind Load [lb/ft]	Vertical Load [lb]	Wind Load [lb/ft]	Vertical Load [lb]	Wind Load [lb/ft]	Vertical Load [lb]	Wind Load [lb/ft]	Vertical Load [lb]	Wind Load [lb/ft]	
L/360	7	5513	131.2	8269	196.8	11025	262.3	8269	442.7	12403	664.1	16538	885.4	11025	1049.4	16538	1574.1	22050	2098.8	
	8	5513	87.9	8269	131.8	11025	175.8	8269	296.6	12403	444.9	16538	593.2	11025	703.0	16538	1054.5	22050	1406.0	
	9	5513	61.7	8269	92.6	11025	123.4	8269	208.3	12403	312.4	16538	416.6	11025	493.7	16538	740.6	22050	987.5	
	10	5513	45.0	8269	67.5	11025	90.0	8269	151.8	12403	227.8	16538	303.7	11025	359.9	16538	539.9	22050	719.9	
	11	5113	33.8	7670	50.7	10226	67.6	8269	114.1	12403	171.1	16538	228.2	11025	270.4	16538	405.6	22050	540.9	
	12	4383	26.0	6575	39.1	8765	52.1	8269	87.9	12403	131.8	16538	175.8	11025	208.3	16538	312.4	22050	416.6	
	13	3799	20.5	5699	30.7	7597	41.0	8269	69.1	12403	103.7	16538	138.2	11025	163.8	16538	245.7	22050	327.7	
	14	3324	16.4	4987	24.6	6648	32.8	8269	55.3	12403	83.0	16538	110.7	11025	131.2	16538	196.8	22050	262.3	
	15							8269	45.0	12403	67.5	16538	90.0	11025	106.6	16538	160.0	22050	213.3	
	16							8195	37.1	12016	55.6	16021	74.1	11025	87.9	16538	131.8	22050	175.8	
	17							7362	30.9	10802	46.4	14405	61.8	11025	73.3	16538	109.9	22050	146.5	
	18							6649	26.0	9764	39.1	13022	52.1	11025	61.7	16538	92.6	22050	123.4	
	19							6034	22.1	8869	33.2	11829	44.3	11025	52.5	16538	78.7	22050	105.0	
	20							5500	19.0	8096	28.5	10793	38.0	11025	45.0	16538	67.5	22050	90.0	
	21							5036	16.4	7416	24.6	9887	32.8	11025	38.9	16538	58.3	21781	77.7	
	22													10276	33.8	15422	50.7	20090	67.6	
	23													9500	29.6	14249	44.4	18585	59.2	
	24													8807	26.0	13209	39.1	17242	52.1	
	L/240	7	5513	196.8	8269	295.1	11025	393.5	8269	664.1	12403	996.1	16538	1328.1	11025	1574.1	16538	2361.1	22050	3148.1
		8	5513	131.8	8269	197.7	11025	263.6	8269	444.9	12403	667.3	16538	889.7	11025	1054.5	16538	1581.8	22050	2109.0
		9	5513	92.6	8269	138.9	11025	185.2	8269	312.4	12403	468.7	16538	624.9	11025	740.6	16538	1110.9	22050	1481.2
		10	5359	67.5	8037	101.2	10718	135.0	8269	227.8	12403	341.7	16538	455.5	11025	539.9	16538	809.9	22050	1079.8
		11	4581	50.7	6870	76.1	9162	101.4	8269	171.1	12403	256.7	16538	342.3	11025	405.6	16538	608.5	22050	811.3
		12	3959	39.1	5937	58.6	7917	78.1	8269	131.8	12403	197.7	16538	263.6	11025	312.4	16538	468.7	22050	624.9
13		3455	30.7	5180	46.1	6908	61.4	8269	103.7	12403	155.5	16538	207.3	11025	245.7	16538	368.6	22050	491.5	
14		3040	24.6	4559	36.9	6080	49.2	8269	83.0	12403	124.5	16538	166.0	11025	196.8	16538	295.1	22050	393.5	
15								8191	67.5	11861	101.2	15814	135.0	11025	160.0	16538	240.0	22050	319.9	
16								7357	55.6	10680	83.4	14240	111.2	11025	131.8	16538	197.7	22050	263.6	
17								6646	46.4	9664	69.5	12886	92.7	11025	109.9	16538	164.8	22050	219.8	
18								6033	39.1	8785	58.6	11714	78.1	11025	92.6	16538	138.9	22050	185.2	
19								5496	33.2	8019	49.8	10693	66.4	11025	78.7	16538	118.1	22050	157.4	
20								5035	28.5	7348	42.7	9799	56.9	10800	67.5	16198	101.2	20830	135.0	
21								4623	24.6	6758	36.9	9012	49.2	9971	58.3	14952	87.4	19258	116.6	
22														9227	50.7	13844	76.1	17853	101.4	
23														8566	44.4	12850	66.6	16594	88.7	
24														7966	39.1	11959	58.6	15461	78.1	
L/180		7	5513	262.3	8269	393.5	11025	524.7	8269	885.4	12403	1328.1	16538	1770.8	11025	1697.2	16538	2598.3	22050	3171.0
		8	5513	175.8	8269	263.6	11025	351.5	8269	593.2	12403	889.7	16538	1186.3	11025	1299.4	16538	1989.4	22050	2427.8
		9	5513	123.4	8269	185.2	11025	246.9	8269	416.6	12403	624.9	16538	833.2	11025	987.5	16538	1481.2	22050	1918.3
		10	4751	90.0	7125	135.0	9501	180.0	8269	303.7	12403	455.5	16538	607.4	11025	719.9	16538	1079.8	22050	1439.8
		11	4109	67.6	6163	101.4	8217	135.2	8269	228.2	12403	342.3	16538	456.3	11025	540.9	16538	811.3	22050	1081.7
		12	3584	52.1	5375	78.1	7168	104.1	8269	175.8	12403	263.6	16538	351.5	11025	416.6	16538	624.9	22050	833.2
	13	3151	41.0	4726	61.4	6302	81.9	8269	138.2	12403	207.3	16538	276.5	11025	327.7	16538	491.5	22050	655.3	
	14	2791	32.8	4185	49.2	5581	65.6	8111	110.7	11540	166.0	15387	221.4	11025	262.3	16538	393.5	22050	524.7	
	15							7310	90.0	10448	135.0	13930	180.0	11025	213.3	16538	319.9	22050	426.6	
	16							6616	74.1	9491	111.2	12655	148.3	11025	175.8	16538	263.6	22050	351.5	
	17							6017	61.8	8653	92.7	11537	123.6	11025	146.5	16538	219.8	22050	293.0	
	18							5490	52.1	7916	78.1	10555	104.1	11025	123.4	16538	185.2	21172	246.9	
	19							5029	44.3	7267	66.4	9689	88.6	10366	105.0	15548	157.4	19647	209.9	
	20							4622	38.0	6692	56.9	8922	75.9	9599	90.0	14405	135.0	18261	180.0	
	21							4261	32.8	6181	49.2	8241	65.6	8916	77.7	13375	116.6	17004	155.5	
	22													8292	67.6	12446	101.4	15862	135.2	
	23													7737	59.2	11607	88.7	14825	118.3	
	24													7231	52.1	10847	78.1	13882	104.1	
	L/120	7	4634	393.5	6936	590.3	9266	787.0	8269	996.9	12403	1381.2	16538	1841.6	11025	1697.2	16538	2598.3	22050	3171.0
		8	4435	263.6	6645	395.4	8869	527.3	8269	763.2	12403	1057.5	16538	1410.0	11025	1299.4	16538	1989.4	22050	2427.8
		9	4056	185.2	6078	277.7	8104	370.3	8133	603.1	11596	835.6	15485	1114.1	11025	1026.7	16538	1571.8	22050	1918.3
		10	3643	135.0	5462	202.5	7282	270.0	7719	455.5	9429	676.8	12587	902.4	11025	831.6	16538	1273.2	22050	1553.8
		11	3257	101.4	4883	152.1	6511	202.8	7533	342.3	9520	513.4	12715	684.5	11025	687.3	16538	1052.2	22050	1284.1
		12	2912	78.1	4366	117.2	5822	156.2	7135	263.6	9344	395.4	12471	527.3	10342	577.5	15906	884.2	20647	1079.0
13		2610	61.4	3914	92.2	5218	122.9	6662	207.3	8920	311.0	11893	414.7	9560	491.5	14306	737.2	17619	919.4	
14		2347	49.2	3520	73.8	4693	98.4	6181	166.0	8402	249.0	11204	332.0	9654	393.5	14483	590.3	15542	787.0	
15								5717	135.0	7860	202.5	10481	270.0	9471	319.9	14185	479.9	15894	639.9	
16								5279	111.2	7327	166.8	9771	222.4	9137	263.6	13705	395.4	15767	527.3	
17								4879	92.7	6820	139.1	9097	185.4	8731	219.8	13089	329.7	15368	439.6	
18								4520	78.1	6348	117.2	8468	156.2	8294	185.2	12428	277.7	14818	370.3	
19								4190	66.4	5912	99.6	7888	132.8	7851	157.4	11780	236.1	14192	314.9	
20								3891	56.9	5512	85.4	7355	113.9	7422	135.0	11133	202.5	13536	270.0	
21								3620	49.2	5150	73.8	6867	98.4	7000	116.6	10513	174.9	12877	233.2	
22														6615	101.4	9926	152.1	12233	202.8	
23														6251	88.7	9373	133.1	11612	177.5	
24														5906	78.1	8856	117.2	11033	156.2	

### Notes

- Column analysis per 2005 National Design Specification (NDS) for Wood Construction.
- Allowable loads are based upon one-piece (solid) columns used in dry service conditions.
- Install columns with depth (second

## VERSA-STUD® 1.7 2650 Nail Design Values

Nail Type	Nail Diameter	Nail Length	Lateral Capacity [lb]	Lateral End Grain Capacity [lb]	Lateral Toe-Nail Capacity [lb]
8d box	0.113"	2.5"	116	78	96
8d common	0.131"	2.5"	143	96	119
10d box	0.128"	3"	148	99	123
10d common	0.148"	3"	188	126	156
12d box	0.128"	3.25"	148	99	123
12d common	0.148"	3.25"	188	126	156
16d box	0.135"	3.5"	165	111	137
16d sinker	0.148"	3.25"	188	126	156
16d common	0.162"	3.5"	225	151	187

**Notes**

- Nail values per 2005 National Design Specification (NDS) for Wood Construction.
- Nail values based upon a load duration factor of 1.60 and an equivalent specific gravity of 0.5.

- Lateral capacities based upon a side-member thickness of 1½".
- For end grain connections, a reduction factor of 0.67 is applied (NDS 11.5.2).
- For toe-nailed connections, a reduction factor of 0.83 is applied (NDS 11.5.4).

## Wall Connectors

## FRAMING ANGLES

## Simpson Strong-Tie

Model No.	Length	Stud Size	Nailing	Allowable Load [lb]	
				F1	F2
A23	2¾"	3½"	(8) 10d x 1½"	565	585
A34	2½"	3½"	(8) 8d x 1½"	365	280
L30	3"	3½"	(4) 10d	240	240
LS30	3¾"	3½"	(6) 10d	395	-
L50	5"	5½"	(6) 10d	445	445
LS50	4⅞"	5½"	(8) 10d	560	-
L70	7"	7¼"	(8) 10d	565	565
LS70	6⅜"	7¼"	(10) 10d	665	-
L70	7"	7¼"	(8) 10d	565	565

## USP Structural Connectors

Model No.	Length	Stud Size	Nailing	Allowable Load [lb]	
				F1	F2
A3	2¾"	3½"	(8) 10d x 1½"	590	600
AC3	2⅞"	3½"	(4) 10d x 1½"	285	320
MP3	3⅜"	3½"	(6) 10d	485	-
AC5	4⅞"	5½"	(6) 10d x 1½"	555	555
MP5	4⅝"	5½"	(8) 10d	730	-
AC7	6⅛"	7¼"	(8) 10d	740	740
L70	5⅞"	7¼"	(10) 10d	910	-

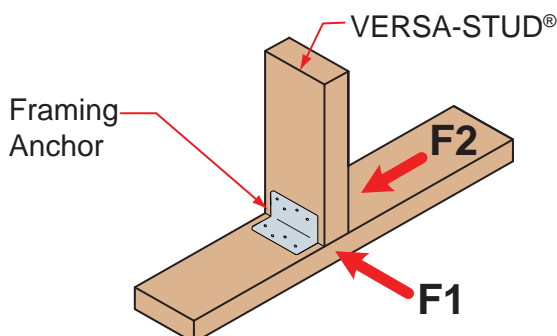

## STUD/PLATE TIES

## Simpson Strong-Tie

Model No.	Nailing	Uplift [lb]
RSP4	(8) 8d x 1½"	315
SSP	(7) 10d x 1½"	350
DSP	(14) 10d x 1½"	775
SP1	(10) 10d	585
SP2	(12) 10d	1065

## USP Structural Connectors

Model No.	Nailing	Uplift [lb]
RSPT4	(8) 8d x 1½"	470
RSPT6	(8) 10d x 1½"	700
RSPT6-2	(14) 10d x 1½"	955
SPT22	(8) 10d	725
SPT24	(12) 10d	1085

## HEADER CLIPS/HANGERS

## Simpson Strong-Tie

Model No.	Width	Nailing	Allow Vertical Load [lb]
FC4	3 <sup>9</sup> / <sub>16</sub> "	(8) 16d	800
FC6	5½"	(10) 16d	920
HH4	3½"	(13) 16d	1195
HH6	5½"	(18) 16d	1595

## USP Structural Connectors

Model No.	Width	Nailing	Allow Vertical Load [lb]
SFC4	3 <sup>9</sup> / <sub>16</sub> "	(8) 16d	550
SFC6	5½"	(10) 16d	690
HH44	3 <sup>9</sup> / <sub>16</sub> "	(13) 16d	1240
HH66	5½"	(18) 16d	1650

Connection values based upon a load duration factor of 1.6 and an equivalent specific gravity of 0.5.

## Base and Top Lateral Wind Reactions for Connectors [lb] 20 PSF Wind Load

See footnote 1 for conversions for other wind loads

Height [ft]	Stud / Column Tributary Width [in]										Note
	12	16	19.2	24	36	48	60	72	84	96	
8	80	107	128	160	240	320	400	480	560	640	1) For other wind loads, multiply reaction in table by the following factors: 10 PSF = 0.5 15 PSF = 0.75 25 PSF = 1.25 30 PSF = 1.5 40 PSF = 2.0
10	100	133	160	200	300	400	500	600	700	800	
12	120	160	192	240	360	480	600	720	840	960	
14	140	187	224	280	420	560	700	840	980	1120	
16	160	213	256	320	480	640	800	960	1120	1280	
18	180	240	288	360	540	720	900	1080	1260	1440	
20	200	267	320	400	600	800	1000	1200	1400	1600	
22	220	293	352	440	660	880	1100	1320	1540	1760	
24	240	320	384	480	720	960	1200	1440	1680	1920	

## VERSA-STUD® Allowable Holes and Notches

### Prescriptive Provisions

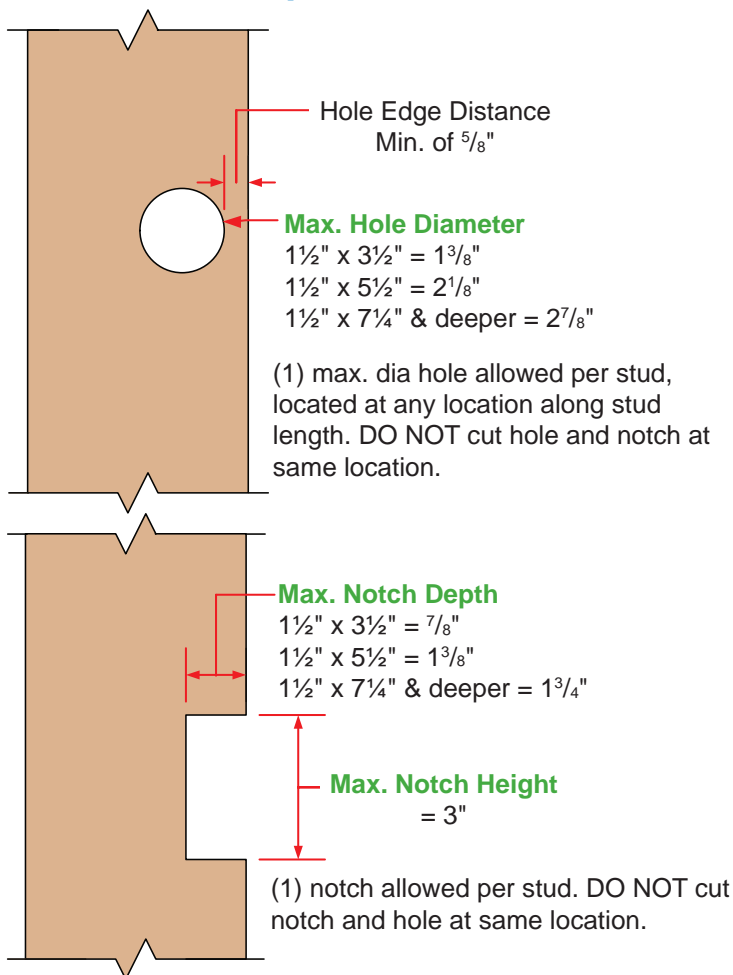

**Notes:**

- 1) Provisions valid only for studs within prescriptive design (see page 3).
- 2) Shield plates or nail stops to prevent nailing into wiring or piping shall be installed per the governing building code.

### Engineered Design Provisions

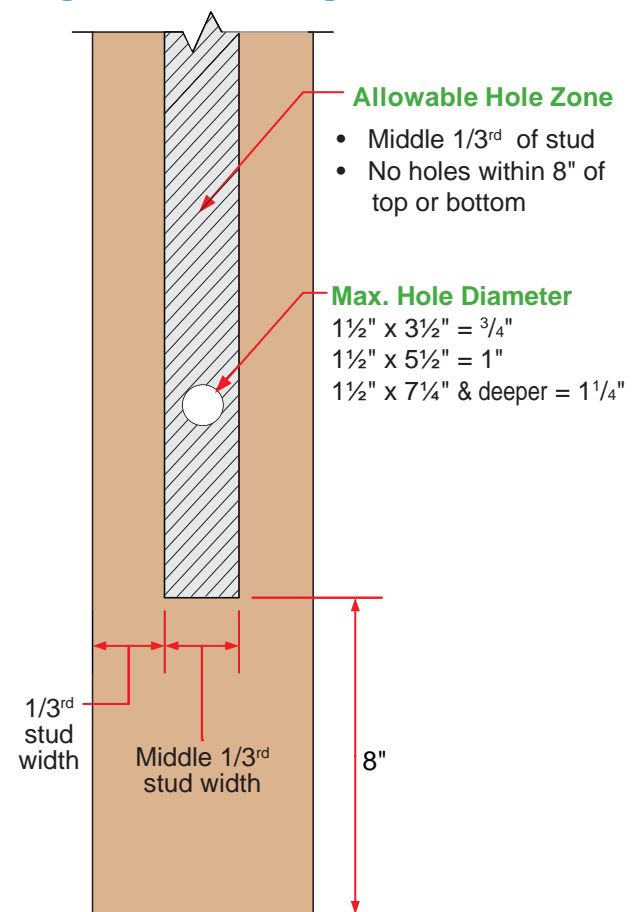

**Notes:**

- 1) DO NOT drill more than 3 holes in any 4-foot-long section of stud.
- 2) The vertical distance between adjacent holes must be at least 2 times the size of the larger hole
- 3) Holes no greater than 3/4" dia may be cut in the hole zone shown in VERSA-LAM® columns.
- 4) For notches and larger holes, contact Boise EWP Engineering.

### 1½" VERSA-STUD® 1.7 2650 Design Properties

Width [in]	Depth [in]	Weight [lb/ft]	Allowable Shear [lb]	Allowable Moment [lb-ft]	Moment of Inertia (I) [in <sup>4</sup> ]
1½	3½	1.5	998	776	5.4
1½	5½	2.4	1568	1821	20.8
1½	7¼	3.2	2066	3069	47.6
1½	9¼	4.0	2636	4862	98.9
1½	11¼	4.9	3206	7038	178.0

### VERSA-LAM® 1.7 2650 Column Design Properties

Width [in]	Depth [in]	Weight [lb/ft]	Allowable Moment Edge <sup>(1)</sup> [lb-ft]	Allowable Moment Flat <sup>(1)</sup> [lb-ft]	Moment of Inertia (I) [in <sup>4</sup> ]
3½	3½	3.6	1810	1639	12.5
3½	5¼	5.4	3892	3525	42.2
3½	7	7.1	6702	6069	100.0
5¼	5¼	8.0	5838	5287	63.3
5¼	7	10.7	10053	9104	150.1
7	7	14.3	13403	12139	200.1

1) Allowable bending stress is 2650 psi on edge (parallel to gluelines), 2400 psi flat (perpendicular to gluelines)

### Allowable Stress Value Comparison

Product	Bending $F_b$ [psi]	Compression Parallel to Grain $F_c$ [psi]	Compression Perp to Grain $F_{c\perp}$ [psi]	Modulus of Elasticity $E$ [psi]	Horizontal Shear $F_v$ [psi]
<b>VERSA-STUD® 1.7 2650</b>	2650	3000	450	1700000	285
Spruce Pine Fir (North) #1/2 Grade	875	1150	425	1400000	135
Hem-Fir #2 Grade	850	1300	405	1300000	150
Western Woods #2 Grade	675	900	335	1000000	135

- Design values are for loads applied to the narrow face of the studs.
- Dimension lumber values taken from 2005 Edition, NDS Design Values for Wood Construction. (per 2006 IBC/IRC)
- Repetitive member and size factors have not been applied.





## Prescriptive Nailing

Since VERSA-STUD® may be used in prescriptive design in the IBC and IRC, it may be installed as studs in braced wall panels. Standard nailing for prescriptive wood stud walls with structural sheathing is 6d common nails for panels  $\frac{5}{16}$ " to  $\frac{1}{2}$ " thick, 8d common nails for panels  $\frac{19}{32}$ " to 1" thick, spaced at 6" on-center on panel edges and 12" on-center in intermediate studs.

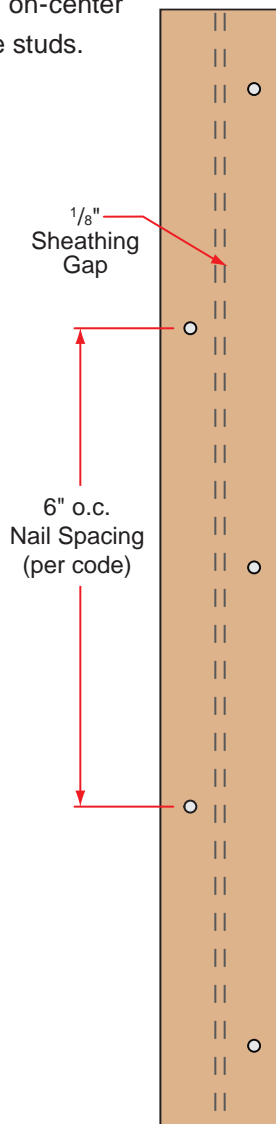

**Single Stud Nailing at Panel Edges**

## Shear Walls

VERSA-STUD® may be used in shear wall construction. Allowable shear values may be determined by using Table 2306.4.1 of the IBC, shear walls with Douglas fir-Larch framing, subject to the following conditions:

1. A double VERSA-STUD® must be used at all panel edges of shear walls. Studs must be stitch-nailed together with two rows of 10d common nails at 8" on-center, staggered.
2. Nails at panel edges must be staggered along two nailing lines spaced approximately  $\frac{1}{2}$ " apart. Nails at panel edges must also be at least  $\frac{3}{8}$ " from the edges of the VERSA-STUD® and the wood structural panel (see detail below).
3. The tabulated shear values for nailed wood structural panel shear walls using 8d or 10d box or common nails at a panel edge nailing of 2" must be multiplied by a factor of 0.9.
4. The tabulated shear values for nailed wood structural panel shear walls using 10d box or common nails at a panel edge nailing of 3" must be multiplied by a factor of 0.9.

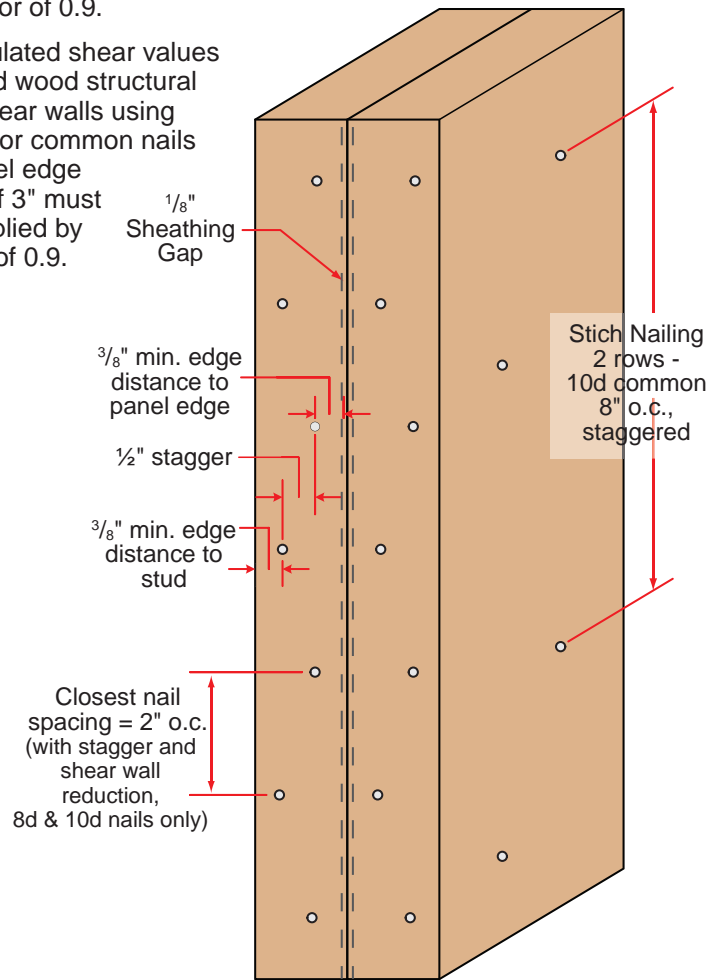

**Double Stud Nailing Edges Shear Wall Only**

## Fire Assemblies

VERSA-STUD® are permitted as a direct replacement for solid-sawn lumber in any fire-resistance-rated wall assembly listed in Table 720.1(2) of the IBC, provided the VERSA-STUD® have a minimum depth of  $\frac{5}{2}$ ".

Boise Cascade EWP is proud to introduce BC COLUMN®. BC COLUMN® is new software that will allow customers the ability to design columns using Boise Cascade Engineered Wood Products.



### Using BC COLUMN®, users can quickly:

- Design a column or stud using Boise Cascade Engineered Wood Products.
- Add gravity and out-of-plane lateral loads.
- Add bracing/supports.
- Select and test products in the design.
- Refine performance factors.
- Print design reports.

### The steps are simple. To use:

- Set up the project:
- Launch BC COLUMN®.
- Enter project information.
- Specify the design and select a product.
- Describe the type of column or stud, its height and its bracing.
- Adjust the axial load and add additional out-of-plane lateral loads.
- Select a product. Specify the Deflection.
- Specify the column/stud deflection.
- Analyze and refine designs.
- Review and print design reports.

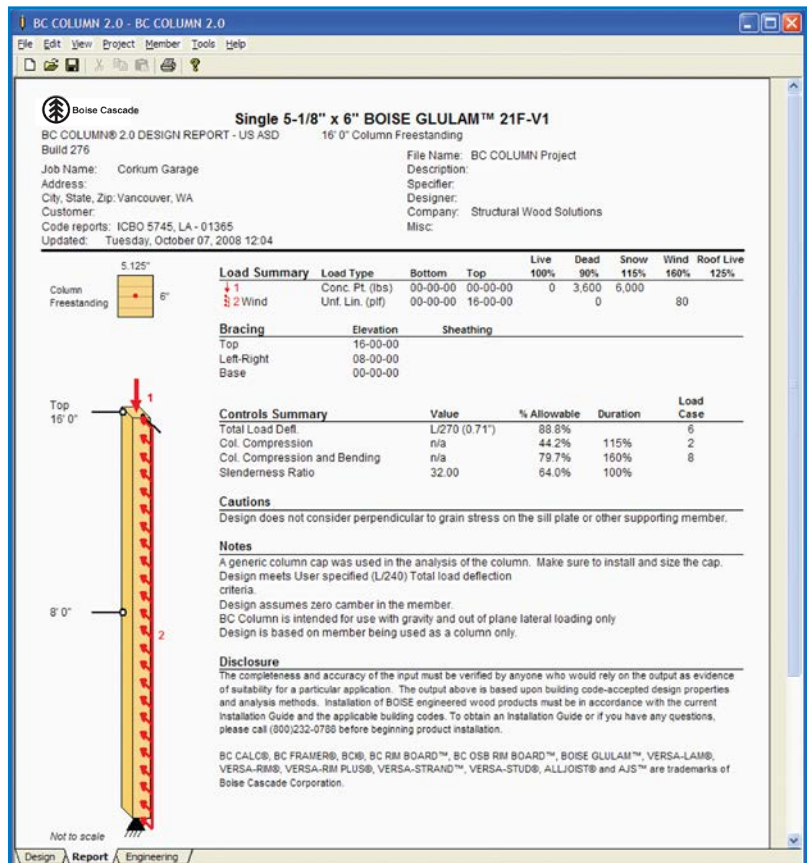
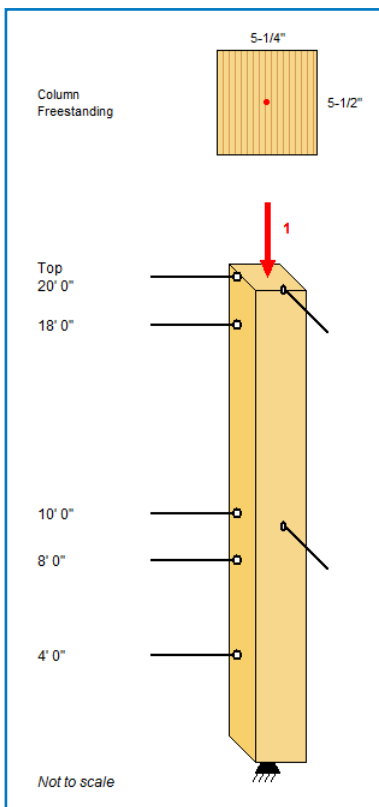
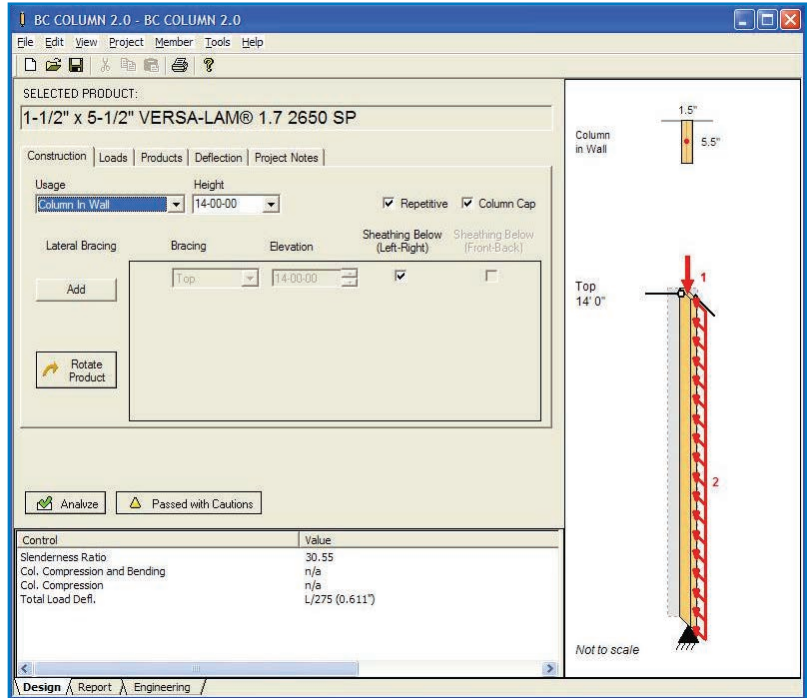

BC COLUMN® is installed with BC CALC for the US market ONLY.

To request a CD or Download of BC CALC/BC COLUMN US

<http://www.bc.com/wood/ewp/software/bccalc/order/US-form.html>

## BC FRAMER® CADD Framing Software

BC FRAMER® is an easy-to-use, stand-alone computer-aided drafting program with 3D capability designed to quickly create floor and roof framing layouts.

Draw walls, add framing areas, locate beams and rough openings, define cross-sections and on-center spacing. In minutes, BC FRAMER® frames your layout, builds a piece and price report, creates a framing drawing with schedule, all using Boise Cascade Engineered Wood Products.

Easy-to-use editing and drawing tools allow flexibility when modifying members and adding details, symbols and accessories.

Training classes for BC FRAMER® are provided at Boise Cascade's training centers located in Oregon, Louisiana and Georgia.

For questions, comments or a free demonstration CD visit our website at [www.bcewp.com](http://www.bcewp.com) or email us at [EWPSupport@BC.com](mailto:EWPSupport@BC.com). Information can also be obtained at 1-800-405-5969.

**RECOMMENDED HARDWARE**

- Current Pentium Processor
- 2GB RAM (min.)
- Microsoft® Intellimouse
- Windows 7, Vista or XP Professional

Improvements in capacity or speed of these components will yield better performance.

**Give Us a Try!**

## BC CALC® Sizing Software

BC CALC® is Boise Cascade's sizing software for BCI® Joists and VERSA-LAM® Beams.

BC CALC® is simple to use, yet flexible enough to analyze most joist and beam applications. Span, load and hole information entered by the user is analyzed by the program to correctly size Boise Cascade Engineered Wood Products. A comprehensive Help File menu is included in the program.

BC CALC® is available to designers, architects and engineers on CD-ROM or by download at [www.bcewp.com](http://www.bcewp.com). Hardware requirements include a minimum of 1GB RAM. To order BC CALC®, call 1-800-405-5969 or email [EWPSupport@BC.com](mailto:EWPSupport@BC.com).

**To request a CD or Download of BC CALC US, <http://www.bc.com/wood/ewp/software/bccalc/order/US-calc-form.html>**

**BC CALC - [JO1 - R1-Design-View.BCC]**

- Use the New Design toolbar to create a new design
- Use the Loads toolbar to add loads
- Use the Holes toolbar to add holes
- Member Diagram: Same as BC CALC 2001a
- Double-Click on Analysis to analyze design
- Double-Click on Cautions to analyze design and display Report
- Double-Click on any item to display and change design parameters
- View tabs - Click or Ctrl+D, Ctrl+R, Ctrl+E to see the Design window, Report, or Engineering Data
- Project Manager tab
- Design Tabs - Each design has its own. Click or Ctrl+Arrow to select.

**BC CALC - [R1-Project Manager Section1.BCC]**

- Click Print button to print selected designs
- Create sub-folders to organize your designs
- Double-click on design name or icon to go to a design
- Use the Hide/Show checkboxes to hide or open Window menu to hide/show all designs
- Click here to enter project information
- Open Window menu to hide/show all designs
- Click to analyze all designs
- Drag column border to resize;
- Drag column heading to move;
- Right-Click to add/drop columns
- Right-Click in the Designs column to create new folders and designs
- Columns show analysis results, double-click to go to design

**Project Manager Window**

Designs	Analysis	Cautions	Product	# Memb.	Total Def.	Live Def.	Moment	End React.	Int. React.
F1	Passed	No	8" x 14" V-L 3000 DF	1	L/1302 (0.0)	L/1658 (0.0)	25.5%	-	-
F2	Passed	No	8" x 18" V-L 2000 DF	1	L/1419 (0.0)	L/1783 (0.0)	36.4%	-	-
F3	Passed	No	16" BC 450 DF	1	L/2545 (0.0)	L/2574 (0.0)	24.0%	37.4%	-
F4	Passed	No	16" BC 500 DF	1	L/1799 (0.0)	L/2236 (0.0)	25.5%	45.5%	-
F5	Passed	No	8" x 11 7/8" V-L 3000 DF	1	L/910 (0.5)	L/255 (0.0)	70.8%	-	-
F6	Failed	Yes	8" x 11 7/8" V-L 2500 DF	1	L/270 (0.5)	L/237 (0.0)	112.5%	-	-
F7	Failed	Yes	8" x 13 1/2" G-Lam 2	1	L/556 (0.2)	L/795 (0.0)	48.5%	-	-
F8	Failed	No	7/8" BC 600 DF	1	L/1077 (0.0)	L/1346 (0.0)	32.7%	39.7%	-
F9	Passed	No	14" BC 650 DF	1	L/1400 (0.0)	L/2417 (0.0)	33.6%	42.3%	-
F10	Passed	No	14" BC 450 DF	1	L/229 (0.2)	L/1354 (0.0)	40.8%	40.5%	-
F11	Passed	No	3 1/2" x 11 7/8" V-L 2000 DF	1	L/929 (0.1)	L/1547 (0.0)	28.4%	-	-
F12	Failed	Yes	3 3/4" x 11 7/8" V-L 2000 DF	1	L/155 (0.8)	L/216 (0.0)	107.5%	-	-
F13	Failed	No	9 3/4" x 18" G-Lam 24F-V	1	L/1154 (0.0)	L/2190 (0.0)	15.9%	-	-

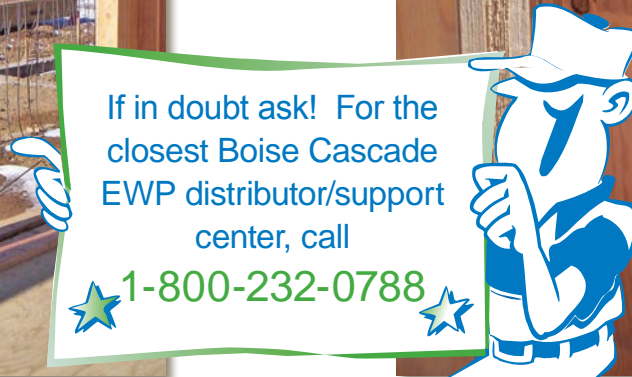

If in doubt ask! For the closest Boise Cascade EWP distributor/support center, call

★ 1-800-232-0788 ★

Boise Cascade EWP is a participant in the Sustainable Forestry Initiative® (SFI®), a comprehensive forest management program that is a combination of environmental responsibilities and sound business practices. The procurement systems of Boise Cascade's engineered wood product facilities have been audited by PricewaterhouseCoopers to the SFI® Standard and its products will carry the SFI® Label. These procurement systems provide tracking information on Boise Cascade's supply chain sources.



**Great products are only the beginning.™**

### Lifetime Guaranteed Quality and Performance

Boise Cascade warrants its BCI® Joist, VERSA-LAM®, and ALLJOIST® products to comply with our specifications, to be free from defects in material and workmanship, and to meet or exceed our performance specifications for the normal and expected life of the structure when correctly stored, installed and used according to our Installation Guide.

For information about Boise Cascade's engineered wood products, including sales terms and conditions, warranties and disclaimers,

**visit our website at [www.BCewp.com](http://www.BCewp.com)**

BOISE CASCADE, TREE-IN-A-CIRCLE, BCI, BC CALC, BC FRAMER, BC RIM BOARD, BOISE GLULAM, SIMPLE FRAMING SYSTEM, VERSA-LAM, VERSA-RIM, VERSA-STRAND, and VERSA-STUD are trademarks of Boise Cascade, L.L.C. or its affiliates.

Your Dealer is:

If no dealer is listed, call 1-800-232-0788



**Boise Cascade**  
Engineered Wood Products